

1-1-2006

## Controlling Rail Potential of DC Supplied Rail Traction Systems

MEHMET TURAN SÖYLEMEZ

SÜLEYMAN AÇIKBAŞ

ADNAN KAYPMAZ

Follow this and additional works at: <https://journals.tubitak.gov.tr/elektrik>



Part of the [Computer Engineering Commons](#), [Computer Sciences Commons](#), and the [Electrical and Computer Engineering Commons](#)

---

### Recommended Citation

SÖYLEMEZ, MEHMET TURAN; AÇIKBAŞ, SÜLEYMAN; and KAYPMAZ, ADNAN (2006) "Controlling Rail Potential of DC Supplied Rail Traction Systems," *Turkish Journal of Electrical Engineering and Computer Sciences*: Vol. 14: No. 3, Article 9. Available at: <https://journals.tubitak.gov.tr/elektrik/vol14/iss3/9>

This Article is brought to you for free and open access by TÜBİTAK Academic Journals. It has been accepted for inclusion in Turkish Journal of Electrical Engineering and Computer Sciences by an authorized editor of TÜBİTAK Academic Journals. For more information, please contact [academic.publications@tubitak.gov.tr](mailto:academic.publications@tubitak.gov.tr).

# Controlling Rail Potential of DC Supplied Rail Traction Systems

Mehmet Turan SÖYLEMEZ<sup>1</sup>, Süleyman AÇIKBAŞ<sup>2</sup>, Adnan KAYPMAZ<sup>3</sup>

<sup>1</sup>*İstanbul Technical University, İstanbul-TURKEY*  
*e-mail: soylemez@elk.itu.edu.tr*

<sup>2</sup>*İstanbul ULAŞIM AŞ, İstanbul-TURKEY*  
*e-mail: acikbas@istanbul-ulasim.com.tr*

<sup>3</sup>*İstanbul Technical University, İstanbul-TURKEY*  
*e-mail: kaypmaz@elk.itu.edu.tr*

## Abstract

*Most modern DC electrified mass transit systems use a totally floating earth as their grounding strategy. A well-known problem related with totally floating systems is that the touch potentials can be dangerously high. In order to reduce the voltages on rails, several devices exist. Most of these devices allow a direct connection to earth when a certain voltage threshold is exceeded. In this paper, the working principles of these devices are given and the effect of certain parameters related with these devices on the minimum achievable touch potentials is investigated.*

**Key Words:** *Rail Transit, Earthing, Rail Potential Control, Stray Currents, Touch Voltage*

## 1. Introduction

In the majority of older traction power systems, the rails were not insulated from the ground, and direct connections between the negative busses of substations and the earth were established. Such systems are called directly connected earth systems [1]. The return current passes through mother earth as well as rails in such traction systems. A particular problem related with this strategy is the increase in stray currents, which results in energy loss, and, more importantly, corrosion in surrounding utilities [2, 3].

After the adverse effects of corrosion near mass transit systems were proven, most modern railways started to insulate the negative return system including the rails and negative busses of substations so that the whole system was “floating”. Such systems are called totally floating earth systems. Most DC traction rail systems in continental Europe are totally floating systems [4]. The problem with this strategy, however, is the increase in rail voltages (sometimes to dangerous levels). Therefore, special precautions must be taken when running rails are used as the return current conductor and insulated from the ground. This is usually done by the placing of electronic devices (usually called rail potential control devices (RPCDs)) [1, 5]. The settings of these devices, however, have to be set with great care as there are often limits on the minimum possible touch potential that can be achieved for a given system depending on these settings. In this paper, we discuss the existence of such limits and the effect of several parameters on the rail voltages observed on

a test system with the help of simulation. In particular, the effects of grounding of the RPCDs and the threshold voltage levels used in these devices are investigated.

In the paper, firstly, the simulation program used for the research is introduced, and then the model of the grounding scheme used in simulations is given. After the test system used to do comparisons is described, the working mechanism of RPCDs is briefly given. The existence of the limits on rail potentials and the effect of the quality of RPCD grounding on these limits are discussed with the help of simulations. Finally, the results and recommendations are provided.

## 2. Simulation Program

A DC fed rail mass transit system power network solution involves the solving of numerous non-linear equations. An iterative solution of sparse matrixes whose sizes depend on length of line and selected parameters for examination is usually required in such calculations. This can only be achieved with help of simulation programs.

SimuX [6, 7], the software applied for electrical calculations of DC electrified railway systems, can be utilized for the simulation of multi-line, multi-train systems. SimuX enables users to simulate DC fed rail systems in a user-friendly environment, taking into account the regenerative braking and under-voltage behavior of the vehicles.

All kinds of details including the characteristics of trains and transformers, gradients, curves, passenger stations, properties of power lines and rails, section insulation points, jumpers and depots can be entered into the simulation program to obtain a realistic simulation.

This program has already been used as the basis of several scientific papers (see [1, 8-10]) and 2 industrial projects, showing the considerable capabilities of the developed software.

## 3. Modelling Rail Voltages

In many older traction power systems, the rails were not insulated from the ground, and direct connections between the negative busses of substations and the earth were established. Such systems are called directly connected earth systems. Most modern railways prefer to insulate the negative return system including the rails and negative busses of substations such that the whole system is “floating”. Such systems are called totally floating earth systems. In diode earth systems, the running rails are connected to the earth with the help of a direction device such that the potential difference between the ground and the rail is guaranteed to be smaller than a given threshold. RPCDs are more complicated devices, which allow the connection of the running rails to the earth when certain rail voltage-time characteristics are observed. If a connection is to be made between running rails and the earth, it is usually done in safety critical places such as substations, passenger stations and/or depots.

Usually stray currents and rail voltages are modeled together in a traction rail simulation program. Stray currents occur as a result of the conductance between the running rail and the earth. For loosely insulated systems (such as directly connected earth systems), the conductance between the rail and the ground could be in the range 1-10 S/km, whereas this value can be as low as 0.003 S/km for highly insulated systems (such as floating earth and diode earth systems). For simplicity, rail-ground conductivity is taken as 0.01 S/km throughout this paper.

A way of representing the conductivity between the rail and the ground is to divide the track into

smaller segments called cells, with each cell representing the conductivity by a resistance connected at a single point (see [11, 12]). Figure 1 illustrates a simple model that can be used in simulating stray currents and rail voltages for a single train running on a single track between 2 substations. Here,  $R_{RG}$  represents the resistance between the rail and the ground,  $R_{NG}$  is the resistance between the negative bus of the substation and the ground,  $R_r$  is the resistance of a rail cell, and  $R_{L1}$  and  $R_{L2}$  represent resistance of the catenary line. The length of each cell is given by  $L$ . Smaller values of  $L$  result in better approximations in the simulation. We note that as the train moves along the track the model changes accordingly.

The value of  $R_{NG}$  is small (less than 1 ohm) for directly connected systems, whereas it is high (theoretically infinity) for totally floating systems. There is a third kind of grounding strategy used in practice called the diode earth strategy, where a diode is used instead of the resistance  $R_{NG}$ , in order to restrict the potential difference between the negative bus of the transformers and mother earth. Recent practical and theoretical studies have shown, however, that the diode earth strategies may result in high touch potentials and stray currents at the same time (see [[1, 13, 14]). Therefore, only totally floating systems are considered in the rest of the paper.

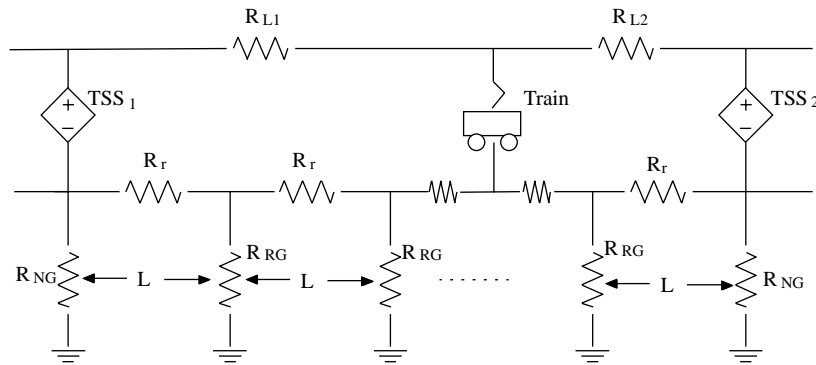


Figure 1. A simple model that can be used for computer simulations of stray currents.

#### 4. Study Case and Simulation Results

In order to be able to view the effects of different settings on touch potentials, a simple system is constructed as shown in Figure 2.

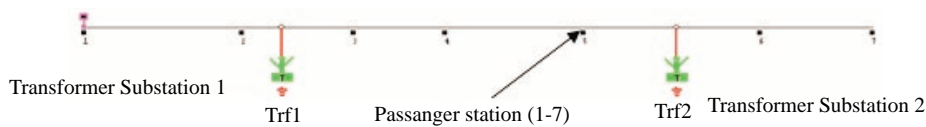


Figure 2. Simulation setup for the basic tests utilized in SimuX.

Here, we consider the case where a single train runs on a single track, powered by 2 substations with 750 VDC nominal voltage. The length of the track is 6 km, and 7 passenger stations are placed unevenly along the track as given in Table 1. The locations of the power substations are selected as 1500 and 4500 m, respectively. It is assumed that there is a 70 kmph speed limit throughout the line. The change in elevation of the track can be seen in Figure 3.

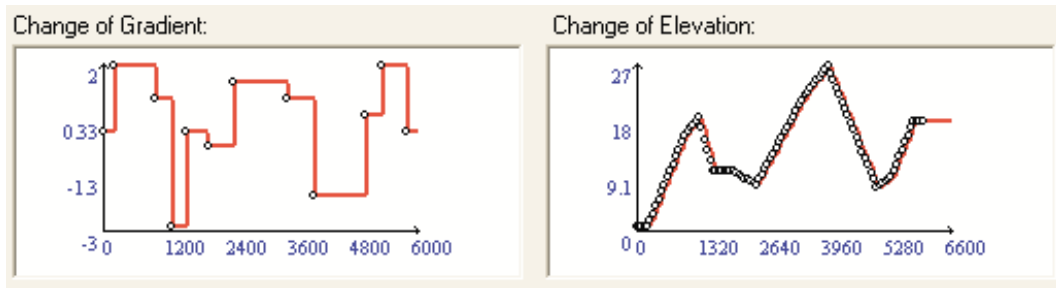


Figure 3. Change in elevation in the simulation study case.

Table 1. Locations of passenger stations in the simulation study case.

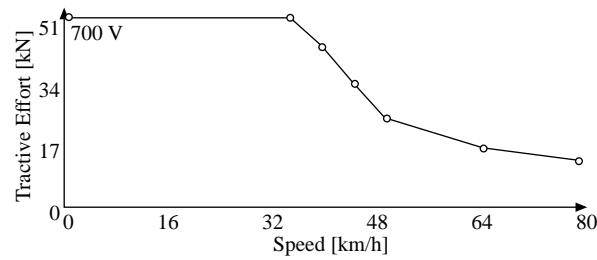
Station No	Location	Station No	Location
1	5 m	5	3800 m
2	1200 m	6	5140 m
3	2050 m	7	5990 m
4	2750 m		

The resistance on the catenary system is taken as  $1.5 \cdot 10^{-5} \Omega/m$  and the rail resistance is assumed to be  $2.06 \cdot 10^{-5} \Omega/m$ . The train is assumed to be constructed from 4 identical vehicles, the main mechanical and electrical characteristics of which are given in Table 2.

Table 2. Vehicle characteristics used in the simulation study case.

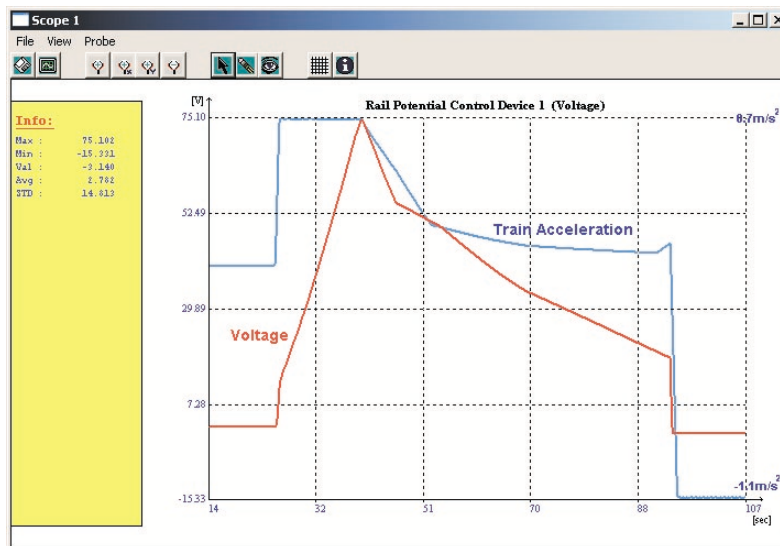
Property:	Value:
Maximum Velocity [km/s]:	80.00
Maximum Acceleration [m/s <sup>2</sup> ]:	0.70
Maximum Deceleration [m/s <sup>2</sup> ]:	1.10
Comfort Rate [m/s <sup>3</sup> ]:	1.00
Loaded Weight [kg]:	50,200
Empty Weight [kg]:	29,000
Length [m]:	23.00
Front Area [m <sup>2</sup> ]:	8.00
Number of Axles	6
Auxiliary Power [kW]:	27.00
Maximum Operating Voltage [V]:	900
Minimum Operating Voltage [V]:	525
Max. Voltage on Braking [V]:	900

Tractive effort produced by one vehicle versus speed can be seen in Figure 4. We remark that this characteristic is dependent on the line voltage, and the simulation program used takes these changes into consideration. The values in Table 2 and curve given in Figure 4 belong to the light rail vehicles used in İstanbul.



**Figure 4.** Tractive Effort (kN) – Speed (km/h) of the train set in the simulation case.

It is possible to show that the maximum rail voltages on this sample track usually occur near the first passenger station (PS1) just after the train accelerates to leave the station. The change in train acceleration and rail voltage at the PS1 are shown in Figure 5. The rail voltage steadily increases as the train accelerates with a constant acceleration rate  $0.7 \text{ m/s}^2$ . A peak value of  $75.1 \text{ V}$  is reached when the train starts to reduce acceleration. It should be noted that in more realistic scenarios, where multiple trains are running on multiple lines, this value can be even higher and might be a risk to human safety. Therefore, a reduction in this peak value is a safety critical problem in many modern railway systems. Application of RPCD is an efficient means of reducing rail voltages, as described in the next section.



**Figure 5.** Change in train acceleration and rail voltage at the first passenger station with no RPCDs installed.

## 5. Rail Potential Control Devices (RPCDs)

On a totally floating system, the potential difference between the rail and the ground needs to be restricted, especially in safety critical places such as depots and passenger stations, to ensure the safety of the personnel and public. This is usually achieved with the help of RPCDs [2]. An illustration of an RPCD is shown in Figure 6. Here, a control unit constantly monitors the potential difference and the flowing current between the rail (or negative bus) and the ground. The switch is open under normal operating conditions (floating earth). When a predefined threshold voltage ( $V_r$ ) is exceeded, the switch is closed to allow current to flow through ground and limit the rail voltage. The RPCD is said to be in the ON position when this happens. The control unit opens the switch back to its normal position only after the current flowing through the

circuit is below a given threshold ( $I_r$ ) and a certain time limit (minimum ON time,  $T_{ON}$ ) has passed. Usually direct connection to earth is not possible and therefore a small resistance ( $R_G$ ) is assumed to exist between the RPCD and the ground. In real-world applications usually the RPCD is switched on after certain voltage-time characteristics are observed. However, for the sake of simplicity in analysis, we assume that a switch on occurs when the threshold is exceeded at least for 250 ms.

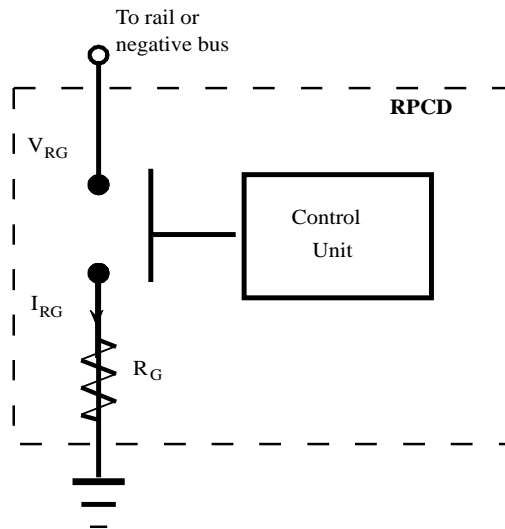


Figure 6. Schematic diagram of the RPCD.

In order to illustrate the working mechanism of RPCDs, an RPCD is placed in each of the passenger stations and the negative bus of the power substations. In order to simplify the analysis, the current and time thresholds are set to  $I_r = 100$  A and  $T_{ON} = 2$  s in the following discussions.

After assuming a very good earthing (by choosing  $R_G = 0.1 \Omega$ ) and setting the voltage threshold to  $V_r = 65$  V, the changes in train acceleration ( $a_T$ ), and voltage ( $V_{RG}$ ) and current ( $I_{RG}$ ) of the rail potential control device located at the first passenger station (RPCD1) are recorded as can be seen in Figure 7. Here, we observe that RPCD1 is switched on immediately after the rail voltage ( $V_{RG}$ ) exceeds the threshold ( $V_r = 65$  V) such that high currents are allowed to pass through the device (around 38 s). This causes the rail voltage to drop to  $V_{RG} = 47$  V. We note that, as in the totally floating case of Figure 5, the rail voltage continues to increase until the train starts to reduce acceleration. However, it never exceeds the threshold value of 65 V. It should also be noted that the RPCD stays in its ON state, until the current  $I_{RG}$  drops below  $I_r = 100$  A at around 94 s.

## 6. Rail Voltage Limit ( $V_{RL}$ )

In the previous section, it was proved that it is possible to reduce the rail voltages of a DC traction power system using a totally floating earth scheme by the help of RPCDs. A natural question that may arise at this stage is whether it is always possible to reduce the rail voltages to any given threshold value for a given system, and, if the answer is no, what are the limits?

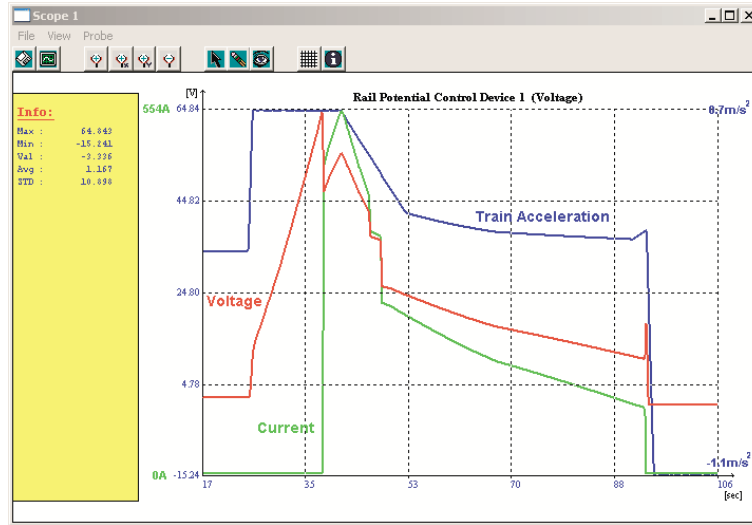


Figure 7. Change in voltage and current on RPCD1 during the acceleration period of the train.

Figure 8 shows the train acceleration ( $a_T$ ), and voltage ( $V_{RG}$ ) and current ( $I_{RG}$ ) of RPCD1 when the voltage threshold is set to  $V_r = 40$  V. We can observe again that as soon as the rail voltage exceeds the threshold at 32 s the RPCD is switched ON and the voltage drops to 30 V. However, since the train continues to accelerate the rail voltage increases from 30 V to  $V_{max} = 53.56$  V until the train reduces acceleration. Therefore, the RPCD cannot restrict the rail voltage at the required level of 40 V.

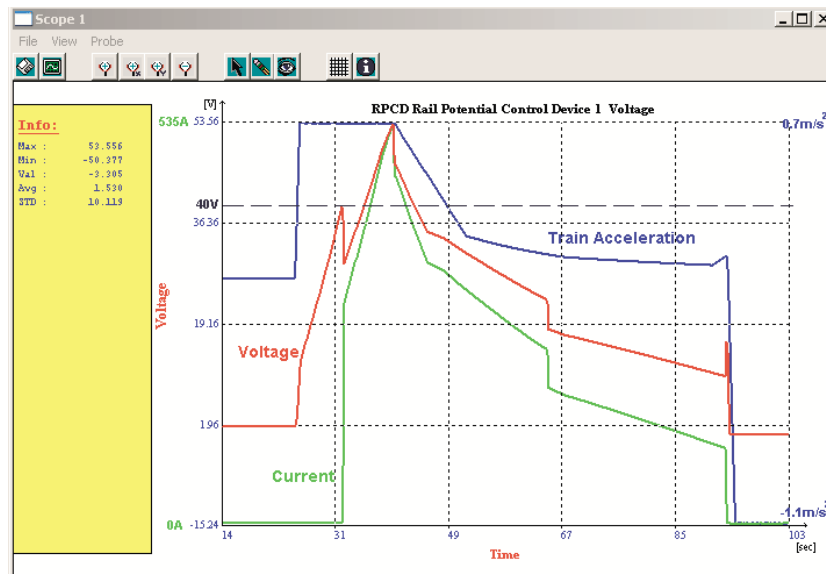
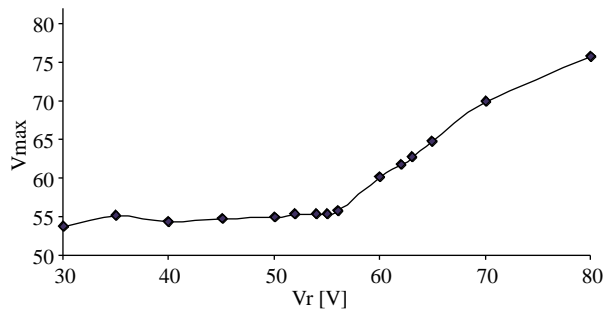


Figure 8. Change in voltage and current on RPCD1 during the acceleration period of the train for  $V_r = 40$  V.

It is possible to obtain the maximum voltage observed on the rails at the first passenger station ( $V_{max}$ ) as a function of the voltage threshold ( $V_r$ ) of all RPCDs used on the track (Figure 9). When this function is examined we see that setting the voltage threshold ( $V_r$ ) below 55 V does not make sense. We say that 55 V is the *rail voltage limit* ( $V_{RL}$ ) for this setup. It is also possible to observe that setting the threshold ( $V_r$ ) below the rail voltage limit increases the overall stray currents since high currents are allowed to pass through RPCDs for a longer period, resulting in higher corrosion rates.





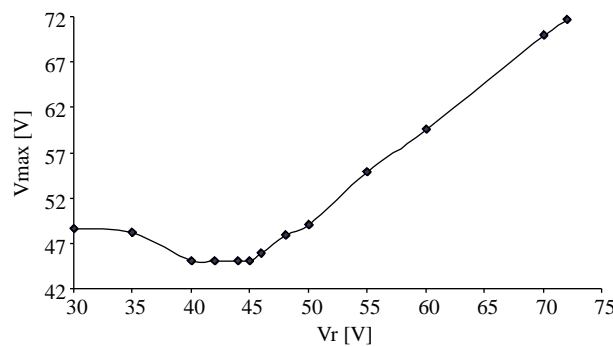
**Figure 9.** Maximum rail voltage vs. voltage threshold of RPCDs ( $V_r$ ) for  $R_G = 0.1 \Omega$  for the simulation study case.

### 7. Grounding of RPCDs and Its Effects on Rail Voltage Limit

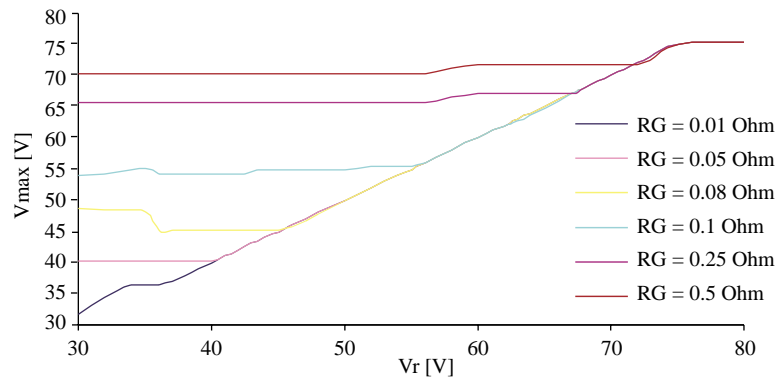
Obviously, the rail voltage limit depends on many parameters including the topology of the line, the maximum distance between power substations, the electrical properties of the rails, and the use of regenerative energy, jumpers and section insulators throughout the line. We will focus on the effect of RPCD grounding on the rail voltage limit in this section.

Normally high returning currents flow through rails when a train accelerates and draws current from a power substation or a nearby decelerating train that produces regenerative power. These currents induce a voltage difference between the rail and the ground. In order to reduce this voltage difference, an alternative path for the returning current is created by RPCDs so that the current flows through mother earth to reach the negative bus of power substations. The resistance on this alternative path is mainly determined by the rail to ground resistance ( $R_G$ ) of RPCDs, which is closely related with how good the grounding system is.

The lower this grounding resistance is, the more currents that flow through the alternative path and hence the less the voltage difference. For instance, the maximum voltage ( $V_{max}$ ) as a function of the voltage threshold ( $V_r$ ) of all RPCDs is given in Figure 10, when  $R_G = 0.08 \Omega$ . Here we see that the rail voltage limit is reduced around  $V_{RL} = 47 \text{ V}$ . The maximum rail voltages for different settings of  $V_r$  and  $R_G$  are given in Figure 11.

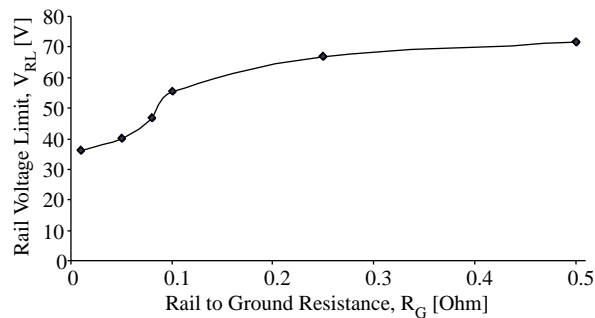


**Figure 10.** Maximum rail voltage vs. voltage threshold of RPCDs ( $V_r$ ) for  $R_G = 0.08 \Omega$ .



**Figure 11.** Maximum rail voltages for different settings of  $V_r$  and  $R_G$  for the simulation study case.

The rail voltage limit as a function of rail to ground resistance for the test system we consider is given in Figure 12. Note that better grounding (lower values of  $R_G$ ) results in lower rail voltage limits, even though the relation is nonlinear. From these graphics, it can be stated that rail to ground resistance should be less than  $0.5 \Omega$  for RPCDs to become effective. A radical drop in rail voltage limit is observed around  $R_G = 0.1 \Omega$ . This is achieved only by employing an extremely good grounding installation. This last point illustrates that the installation and maintenance of grounding in mass transit systems are extremely important and can save lives.



**Figure 12.** Rail voltage limit ( $V_{RL}$ ) vs. rail to ground resistance ( $R_G$ ) for the simulation study case.

## 8. Conclusion

In this paper, the rail voltage reduction on a DC power traction power system that uses a totally floating earth scheme is discussed. In particular, it is shown that RPCDs can provide an efficient mechanism to control the touch potentials. In order for RPCDs to be used efficiently, however, their settings have to be done correctly.

It is shown that usually there are lower limits on voltage thresholds ( $V_r$ ) of RPCDs. Setting the thresholds below these limits would not decrease the rail voltages and would only increase the stray currents. Therefore, adjusting the settings of RPCDs for a particular given system properly (after making simulations) not only saves lives, but also reduces corrosion problems observed at nearby utilities.

It is also shown that the grounding of RPCDs plays an important role in the determination of rail voltage limits. A slight increase in rail to ground resistance might result in considerable increases in touch potentials, which in turn results in safety problems in the system. It is our recommendation that different scenarios be tested by simulation programs and frequent monitoring of rail voltages be carried out in order to ensure the safety of mass transit systems with totally floating earth.

Possible future research includes examination of stray currents at different settings of RPCDs and the effects of regenerative braking on rail voltages and stray currents.

## References

- [1] M.T. Söylemez, S. Açıkbaş. "Comparison of Stray Currents and Rail Voltage Profiles between 750 VDC and 1500 VDC Power Supply Systems Using Simulation", *IEE International Conference on Railway Engineering (ICRE 2005)*, Hong Kong, 2005.
- [2] J.G. Yu. "The Effects of Earthing Strategies on Rail Potential and Stray Currents in D.C. Transit Railways", *Int. Conf. on Developments in Mass Transit Systems*, pp. 303-309, 1998.
- [3] K.J. Moody. "Stray Current Characteristics of Grounded, Ungrounded, and Diode Grounded DC Transit Systems", *Stray Current Corrosion: The Past, Present and Future of Rail Transit Systems*, Houston, Texas, pp. 331-342, 1994
- [4] K.S. Bahra, R.B. Catlow. "Control of Stray Currents for D.C. Traction Power Systems", *Electrical Railways in a United Europe*, pp. 136-142, 1995.
- [5] D. Paul. "DC Traction Power System Grounding", *IEEE Transactions on Industry Applications*, vol. 38, no 3, 2002.
- [6] M.T. Söylemez, S. Açıkbaş. "Multi-Train Simulation of DC Rail Traction Power Systems with Regenerative Braking", *COMPRAIL*, Dresden, Germany, pp. 941-950, 2004.
- [7] M.T. Söylemez, <http://www.simulatorx.com>, 2004.
- [8] S. Açıkbaş, M. T. Söylemez. "Energy loss comparison between 750 VDC and 1500 VDC power supply systems using rail power simulation", *COMPRAIL*, pp. 951-960 , 2004.
- [9] S. Açıkbaş, M.T. Söylemez. "Upgrading the Rolling Stock—Its Effects on the Traction Power Supply System", *IEE International Conference on Railway Engineering (ICRE 2005)*, Hong Kong, 2005.
- [10] S. Açıkbaş, M.T. Söylemez, "Catenary System Paralleling and its Effect on Power Consumption and Regenerated Energy Recuperation", *4th International Conference on Electrical and Electronics Engineering (ELECO 2005)*, Bursa, Turkey, pp 17-21, 2005.
- [11] K.D. Pham, R.S. Thomas, W.E. Stinger. "Analysis of Stray Current, Track-to-Earth Potentials & Substation Negative Grounding in DC Traction Electrification System", *IEEE/ASME Joint Rail Conference*, pp. 141-160, 2001.
- [12] J.G. Yu, C.J. Goodman. "Modelling of Rail Potential Rise and Leakage Current in DC Rail Transit Systems", *IEE Colloq. on Stray Current Effects of DC Railways and Tramways*, pp. 2/2/1-2/2/6, 1990.
- [13] B.-Y. Ku, T. Hsu. "Computation and Validation of Rail-to-Earth Potential for Diode Grounded DC Traction System at Taipei Rapid Transit System", *ASME/IEEE Joint Rail Conference*, pp. 41-46, 2004.
- [14] C.-H. Lee, H.-M. Wang. "Effects of Grounding Schemes on Rail Potential and Stray Currents in Taipei Rail Transit Systems", *IEE Proc.-Electr. Power Appl.*, vol. 148, No 2, pp. 148-154, 2001.