

Numerical simulations of traveling waves in a counterflow filtration combustion model

Fatih ÖZBAĞ*[†] 

Department of Mathematics, Faculty of Arts and Sciences, Harran University, Şanlıurfa, Turkey

Received: 09.05.2021

Accepted/Published Online: 31.03.2022

Final Version: 05.05.2022

Abstract: We focused on traveling combustion waves that appear in a simplified, one-dimensional combustion model in porous media. The system we consider is a reaction-convection-diffusion system that can be reduced into two-dimension in order to prove traveling waves by phase plane analysis. In previous studies combustion wave velocity was assumed positive and their existence was proven. Also, all possible wave sequences that solve boundary value problems on infinite intervals with constant boundary data were identified. In this study, we generalize the previous work by including the case of negative combustion wave speed and taking the assumption that oxygen is carried faster than temperature. Moreover, we extend the classification of all possible wave sequences by performing numerical simulations using finite difference scheme.

Key words: Traveling wave, counterflow combustion waves, porous media

1. Introduction

Combustion waves appear in the process of enhanced oil recovery. One of the goals behind enhanced recovery is to increase the mobility of the heavy oil by using thermal techniques such as hot fluid injection, steam injection, and air injection. In this paper, we consider the air injection method and identify combustion waves in porous media. Some studies on combustion waves in porous media are [1–3, 5, 10–16, 19].

This paper is focused on combustion waves that appear in a simplified, one-dimensional combustion model in porous media containing initially some solid fuel. In one-dimensional combustion model, when combustion occurs, there are two cases: coflow and counterflow combustion. In the coflow case, combustion front and injected airflow move in the same direction. In the counterflow case, they move in the opposite direction and also combustion wave speed is assumed to be negative.

The model considered here is derived in [8]. It was proposed in [1] and expanded in [6–8, 17, 18]. The system we consider is a reaction-convection-diffusion system that can be reduced into two dimensions in order to prove traveling waves by phase plane analysis. It is expressed by three equations that give temperature, oxygen, and fuel balance laws. In [8, 9], velocity of the oxygen and heat were assumed to be the same, then the existence of coflow and counterflow combustion waves were proven. In [4, 17], it was assumed that oxygen is transported faster than temperature, then the existence of coflow and counterflow combustion waves were proven.

*Correspondence: fozbag@harran.edu.tr

[†]Thanks: the author would like to thank Grigori Chapiro for his help with the numerical code RCD used in this work
2010 *AMS Mathematics Subject Classification*: 35L67, 35C07, 35K57, 34C37, 80A25, 76S05

The present work extends [17] to the counterflow case in the sense of classification of all possible wave sequences that solve boundary value problems. We perform numerical simulations for identified wave sequences. For all numerical simulations, we use a nonlinear Crank–Nicolson implicit finite difference scheme and Newton’s method in each time-step with appropriate wave velocities.

In Section 2, we describe our model and summarize what was done in [17]. We then state the main theorem in [4] about the existence of combustion waves. Contact discontinuities are discussed in Section 4. In addition, we identify all the possible ways that combustion waves and contact discontinuities can combine to produce wave sequences that solve boundary value problems on infinite intervals with constant boundary data. We show that the wave sequences we identify actually occur in numerical simulations. In Section 5, the traveling wave system is reduced to two dimensions, and equilibria are determined.

2. Mathematical model and previous results

Consider a combustion system that has the three dependent variables temperature θ , oxygen Y , and fuel ρ :

$$\partial_t \theta + a \partial_x \theta = \partial_{xx} \theta + \rho Y \Phi, \tag{2.1}$$

$$\partial_t \rho = -\rho Y \Phi, \tag{2.2}$$

$$\partial_t Y + b \partial_x Y = -\rho Y \Phi, \tag{2.3}$$

$$\Phi = \begin{cases} e^{(-1/\theta)}, & \theta > 0 \\ 0, & \theta \leq 0 \end{cases} \tag{2.4}$$

where Φ is unit reaction rate (Arrhenius law), $a > 0$ is velocity of the heat, and $b > 0$ is velocity of the oxygen. We assume $a < b$ as in [4, 17]. We have diffusion term only in equation (2.1) and no diffusion in the others.

Moreover, we normalize ignition temperature to be $\theta = 0$. Therefore, combustion can occur when the temperature is above the ignition temperature $\theta = 0$. Also, this normalization allows us to take the temperature negative.

Solutions with $\rho \geq 0$ and $Y \geq 0$ are considered. Constant boundary conditions of (2.1)–(2.3) on $-\infty < x < \infty$, $0 \leq t$ are

$$(\theta, \rho, Y)(-\infty, t) = (\theta^L, \rho^L, Y^L), \quad (\theta, \rho, Y)(\infty, t) = (\theta^R, \rho^R, Y^R). \tag{2.5}$$

We assume the reaction cannot occur at the boundaries. Therefore, at $x = \pm\infty$, we have either low temperature $\theta \leq 0$ (temperature control or TC), absence of fuel $\rho = 0$ (fuel control or FC), or absence of oxygen $Y = 0$ (oxygen control or OC). Two or all three of these conditions can exist simultaneously at the left or right.

A wave with velocity c is denoted by $(\theta^-, \rho^-, Y^-) \xrightarrow{c} (\theta^+, \rho^+, Y^+)$ where (θ^-, ρ^-, Y^-) is the left state and (θ^+, ρ^+, Y^+) is the right state. In addition, a wave of velocity c that goes, for example, from a left state of type $TC \cap FC$ to a right state of type OC will be indicated by $TC \cap FC \xrightarrow{c} OC$. Also, $TC \cap FC$ state indicates that $\theta \leq 0$, $\rho = 0$ and $Y > 0$ and for OC state $\theta > 0$, $\rho > 0$, and $Y = 0$.

In a wave sequence, we only consider boundary conditions TC , FC , or OC as a first or last state. However, states such as $TC \cap FC$ might appear elsewhere in the sequence as end states of waves.

In [17], two fast, two slow, and two intermediate combustion waves that approach both end states exponentially were found and their existence was proven. Fast combustion waves move faster than oxygen and heat; slow combustion waves have been called reaction-trailing smolder waves [2] and move more slowly

than oxygen and heat; intermediate waves have been called reaction-leading smolder waves [2, 16] and move more slowly than oxygen but faster than heat.

Theorem 2.1 *There exist two fast combustion waves with positive velocity $c_f > b > a$:*

- $FC \xrightarrow{c_f} TC$.
- $OC \xrightarrow{c_f} TC$.

Transitional case is of type $FC \cap OC \xrightarrow{c_f} TC$.

In a fast combustion wave, the right state has a low temperature. When the combustion starts, it runs to the right and leaves a high-temperature zone behind since it is transported faster than heat. Behind the combustion front, the reaction ceases due to the absence of fuel or oxygen. See Figure 1. In [17], the existence of these fronts was proven.



Figure 1. Fast combustion waves; θ = temperature, ρ = solid fuel concentration, Y = oxygen concentration.

Theorem 2.2 *There exist two slow combustion waves with positive velocity $0 < c_s < a$:*

- $FC \xrightarrow{c_s} OC$.
- $TC \xrightarrow{c_s} OC$.

Transitional case is of type $FC \cap TC \xrightarrow{c_s} OC$.

There is no oxygen at the right state of a slow combustion wave. Therefore, the reaction cannot occur ahead of the incoming gas. In fact, the combustion occurs behind the moving oxygen. The combustion front generates a high-temperature zone that is transported ahead of it. The reaction ceases behind the front due to lack of fuel or low temperature. See Figure 2. In [17], the existence of these fronts was proven.

Theorem 2.3 *There exist two intermediate combustion wave with positive velocity c_m , $a < c_m < b$:*

- $FC \xrightarrow{c_m} OC$.



Figure 2. Slow combustion waves; θ = temperature, ρ = solid fuel concentration, Y = oxygen concentration.

- $FC \xrightarrow{c_m} TC$.

Transitional case is of type $FC \xrightarrow{c_m} OC \cap TC$.

In an intermediate combustion wave, as in a fast combustion wave, the heat produced by combustion stays behind the combustion front. Behind the front, the reaction stops because the fuel is entirely consumed. As in a slow combustion wave, the reaction occurs behind the moving oxygen. See Figure 3. In [17], the existence of these fronts was proven.



Figure 3. Intermediate combustion waves; θ = temperature, ρ = solid fuel concentration, Y = oxygen concentration.

3. Counterflow combustion waves

We assume that velocity of the counterflow combustion wave c_c is negative. We give the following two theorems in [4] to use them in the numerical calculations.

Theorem 3.1 *There exist two types of counterflow combustion waves with velocity $c_c < 0$:*

- $TC \xrightarrow{c_c} OC$
- $TC \xrightarrow{c_c} FC$

Transitional case is of type $TC \xrightarrow{c_c} OC \cap FC$.

The following theorem gives more detail about these waves. It was proven in detail in [4].

Theorem 3.2 *Let $0 < a < b$. Assume $a\theta^- + bY^- > 0$.*

1. *Fix $\theta^- \leq 0$, $\rho^- > 0$ and $Y^- > 0$. Then there are numbers $\theta^+ > 0$ and $c_c < 0$ such that there exists a combustion wave of velocity c_c from (θ^-, ρ^-, Y^-) to $(\theta^+, 0, 0)$. Moreover,*

$$\theta^+ = \theta^- + \frac{bY^-\rho^-}{(b-a)Y^- + a\rho^-}, \quad c_c = \frac{bY^-}{Y^- - \rho^-}. \quad (3.1)$$

These combustion waves correspond to $TC \xrightarrow{c_c} FC \cap OC$ waves.

2. *Fix $\theta^- \leq 0$, $\rho^- > 0$ and $Y^- > 0$. There are numbers $\theta^+ > 0$, ρ^+ with $0 < \rho^+ < \rho^-$, and $c_c < 0$ such that there exists a combustion wave of velocity c_c from (θ^-, ρ^-, Y^-) to $(\theta^+, \rho^+, 0)$. Moreover,*

$$\theta^+ = \theta^- + \frac{b - c_c}{a - c_c} Y^-, \quad \rho^+ = \rho^- + \frac{b - c_c}{c_c} Y^-. \quad (3.2)$$

These combustion waves correspond to $TC \xrightarrow{c_c} OC$ waves.

3. *Fix $\theta^- \leq 0$, $\rho^- > 0$ and $Y^- > 0$. There are numbers $\theta^+ > 0$, Y^+ with $0 < Y^+ < Y^-$, and $c_c < 0$ such that there exists a combustion wave of velocity c_c from (θ^-, ρ^-, Y^-) to $(\theta^+, 0, Y^+)$. Moreover,*

$$\theta^+ = \theta^- - \frac{c_c}{a - c_c} \rho^-, \quad Y^+ = Y^- + \frac{c_c}{b - c_c} \rho^-. \quad (3.3)$$

These combustion waves correspond to $TC \xrightarrow{c_c} FC$ waves.

Moreover, there are no combustion waves with $c_c < 0$ of types other than $TC \xrightarrow{c_c} FC \cap OC$, $TC \xrightarrow{c_c} OC$, and $TC \xrightarrow{c_c} FC$.

In the next section, using Theorems 3.1 and 3.2, we show that the wave sequences including counterflow combustion waves actually occur in numerical simulations.

4. Wave sequences with contact waves

We expect the solution to resolve into combustion waves and intervals on which combustion does not occur. On these intervals, the equations decouple, so we expect to observe standing solid fuel concentration patterns, convected oxygen concentration patterns, and temperature waves; the velocities are 0, b , and a , respectively. Across each of these waves, only one variable changes. For simplicity, we follow [8, 17] and call these waves contact discontinuities or contact waves. At the left and right state of a contact discontinuity, at least one of the conditions TC , FC , or OC must hold. For further discussion, see [8, 17].

In constructing wave sequences, the transitional cases will not be used, since one state is not approached exponentially [8]. However, for completeness, they are discussed in the theorems. The left state of the first wave in the sequence and the right state of the last wave in the sequence must be of type TC , FC , or OC . Also, the velocity of the waves must be in increasing order.

In [17], 22 possible wave sequences were listed and supported by numerical simulations. In this study, our goal is to generalize the previous work by including the counterflow combustion waves and complete the diagram of wave sequences presented in [17] by adding the waves that were found in [4]. See Figure 4.

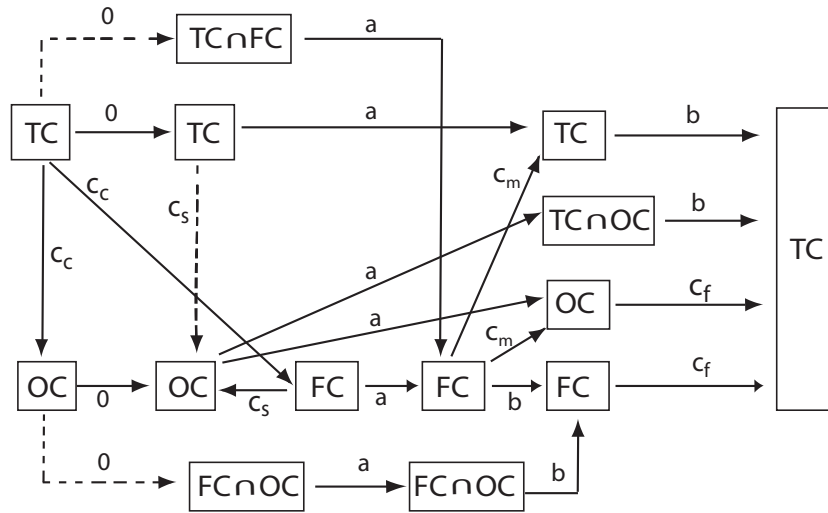

Figure 4. All possible wave sequences can be found from this figure. Dashed and black arrows indicate dimension number 0 and 1, respectively.

In the remainder of this section, we show that the wave sequences including counterflow combustion waves actually occur in numerical simulations. The wave sequences that include a counterflow, an intermediate, and a fast combustion wave, or a counterflow, a slow and a fast combustion wave, are the most complicated.

For all numerical simulations shown below, we use a nonlinear Crank–Nicolson implicit finite difference scheme and Newton’s method in each time-step with $a = 0.01$, $b = 0.05$ and space step $\Delta x = 1.3$. In some numerical examples, we encounter small perturbation in fuel and oxygen concentration because of the initial step adjustment. However, this does not have an effect on the final result.

4.1. Wave sequences with $TC \xrightarrow{c_c} OC$

Using Theorem 3.2(2), we identify three possible wave sequences that contain $TC \xrightarrow{c_c} OC$ counterflow combustion waves and extend the wave sequences as far as possible.

1. $TC \xrightarrow{c_c} OC \xrightarrow{0} OC \xrightarrow{a} TC \cap OC \xrightarrow{b} TC$ wave sequence demonstrates a temperature-controlled to oxygen-controlled stable counterflow combustion wave followed by contact waves of velocities 0, a , and b . See Figure 5.
2. $TC \xrightarrow{c_c} OC \xrightarrow{0} OC \xrightarrow{a} OC \xrightarrow{c_f} TC$ wave sequence demonstrates a temperature-controlled to oxygen-controlled stable counterflow combustion wave and oxygen-controlled to temperature-controlled stable fast combustion wave. Between these combustion waves, there are contact waves of velocities 0 and a . See Figure 6.
3. $TC \xrightarrow{c_c} OC \xrightarrow{0} FC \cap OC \xrightarrow{a} FC \cap OC \xrightarrow{b} FC \xrightarrow{c_f} TC$ wave sequence demonstrates a temperature-controlled to oxygen-controlled stable counterflow combustion wave and fuel-controlled to temperature-

controlled stable fast combustion wave. Between these combustion waves, there are contact waves of velocities 0, a , and b . See Figure 7.

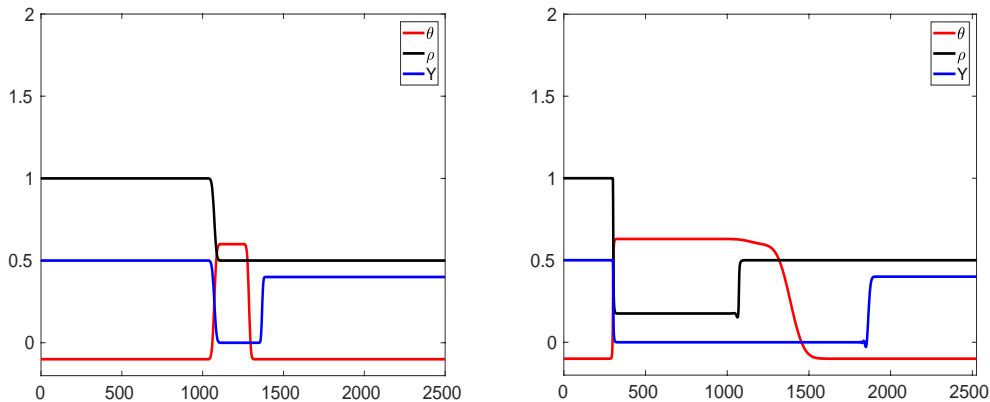

Figure 5. Result of numerical simulation yielding the wave sequence $TC \xrightarrow{c_c} OC \xrightarrow{0} OC \xrightarrow{a} TC \cap OC \xrightarrow{b} TC$. Initial conditions (left) and simulation time 10,000 (right).

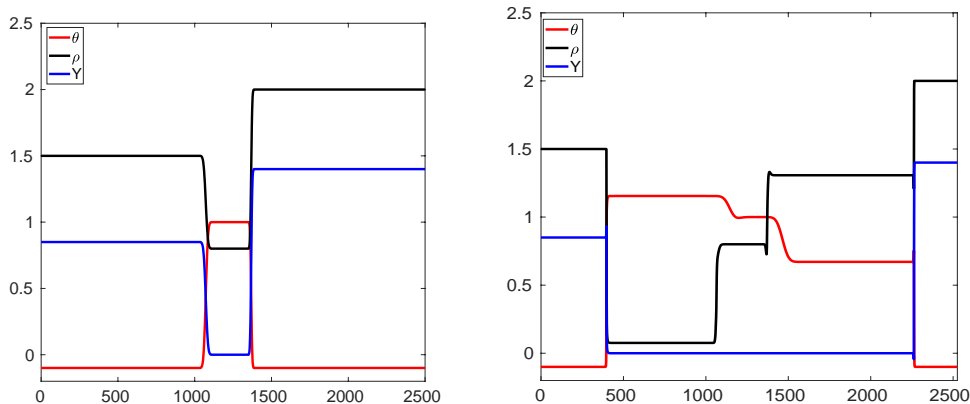

Figure 6. Result of numerical simulation yielding the wave sequence $TC \xrightarrow{c_c} OC \xrightarrow{0} OC \xrightarrow{a} OC \xrightarrow{c_f} TC$. Initial conditions (left) and simulation time 9000 (right).

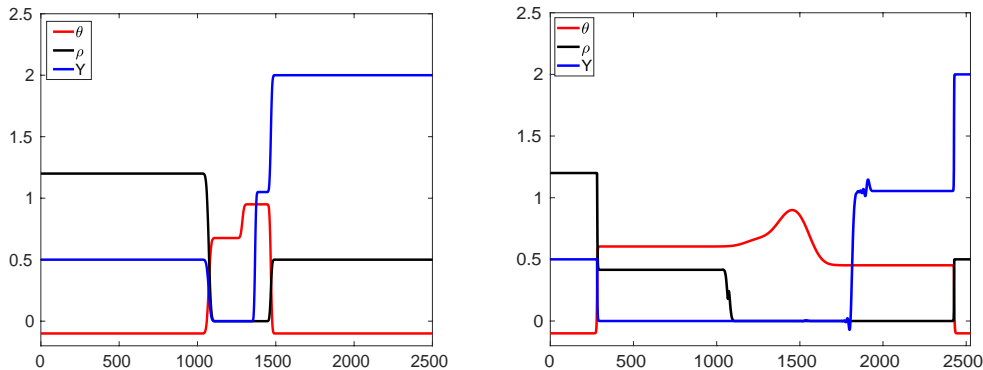

Figure 7. Result of numerical simulation yielding the wave sequence $TC \xrightarrow{c_c} OC \xrightarrow{0} FC \cap OC \xrightarrow{a} FC \cap OC \xrightarrow{b} FC \xrightarrow{c_f} TC$. Initial conditions (left) and simulation time 9000 (right).

4.2. Wave sequences with $TC \xrightarrow{c_c} FC$

Using Theorem 3.2(3), we identify five possible wave sequences that contain $TC \xrightarrow{c_c} FC$ counterflow combustion waves and extend the wave sequences as far as possible.

1. $TC \xrightarrow{c_c} FC \xrightarrow{c_s} OC \xrightarrow{a} TC \cap OC \xrightarrow{b} TC$ wave sequence demonstrates a temperature-controlled to fuel-controlled stable counterflow combustion wave and fuel-controlled to oxygen-controlled stable slow combustion wave followed by contact waves of velocities a and b . See Figure 8.
2. $TC \xrightarrow{c_c} FC \xrightarrow{c_s} OC \xrightarrow{a} OC \xrightarrow{c_f} TC$ wave sequence demonstrates a temperature-controlled to fuel-controlled stable counterflow combustion wave followed by a fuel-controlled to oxygen-controlled stable slow combustion wave, a contact wave of velocity a and an oxygen-controlled to temperature-controlled stable fast combustion wave. See Figure 9.

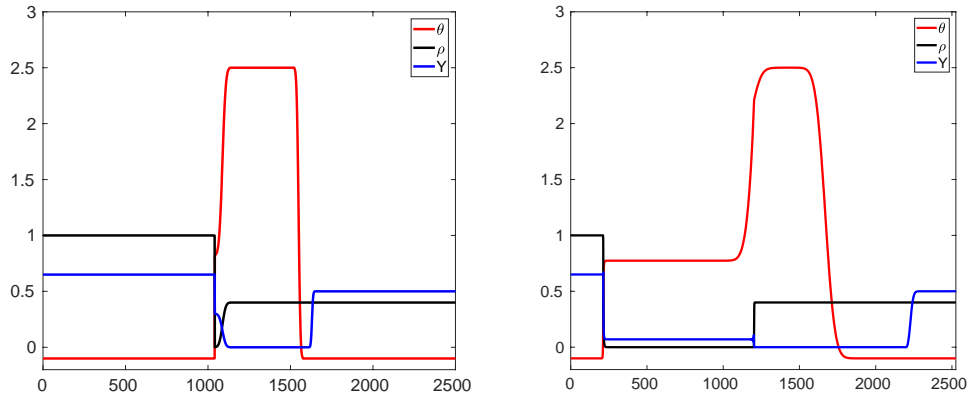

Figure 8. Result of numerical simulation yielding the wave sequence $TC \xrightarrow{c_c} FC \xrightarrow{c_s} OC \xrightarrow{a} TC \cap OC \xrightarrow{b} TC$. Initial conditions (left) and simulation time 12,000 (right).

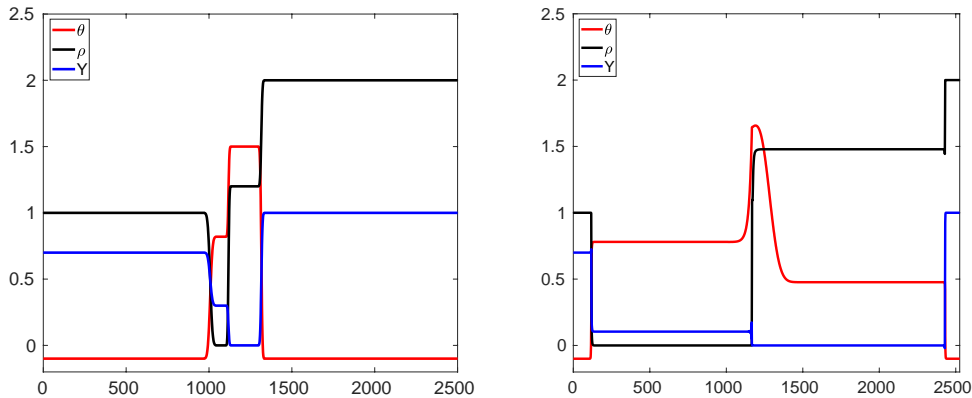

Figure 9. Result of numerical simulation yielding the wave sequence $TC \xrightarrow{c_c} FC \xrightarrow{c_s} OC \xrightarrow{a} OC \xrightarrow{c_f} TC$. Initial conditions (left) and simulation time 12,000 (right).

3. $TC \xrightarrow{c_c} FC \xrightarrow{a} FC \xrightarrow{c_m} TC \xrightarrow{b} TC$ wave sequence demonstrates a temperature-controlled to fuel-controlled stable counterflow combustion wave followed by a contact wave of velocity a , a fuel-controlled to temperature-controlled stable intermediate combustion wave and a contact wave of velocity b . See Figure 10.

4. $TC \xrightarrow{c_c} FC \xrightarrow{a} FC \xrightarrow{c_m} OC \xrightarrow{c_f} TC$ wave sequence demonstrates a temperature-controlled to fuel-controlled stable counterflow combustion wave followed by a contact wave of velocity a , a fuel-controlled to oxygen-controlled stable intermediate combustion wave and an oxygen-controlled to temperature-controlled stable fast combustion wave. See Figure 11.

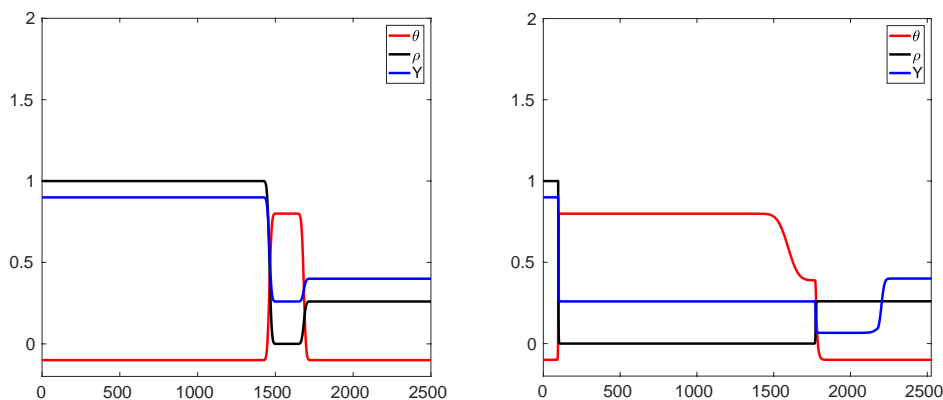

Figure 10. Result of numerical simulation yielding the wave sequence $TC \xrightarrow{c_c} FC \xrightarrow{a} FC \xrightarrow{c_m} TC \xrightarrow{b} TC$. Initial conditions (left) and simulation time 15,000 (right).

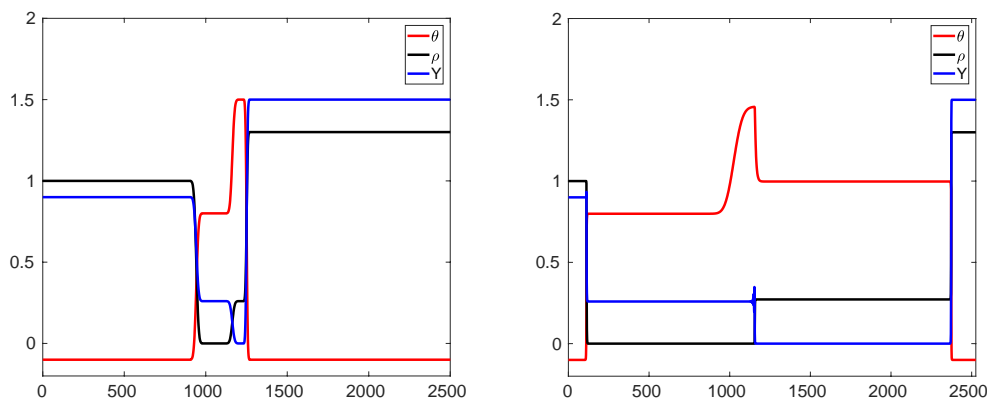

Figure 11. Result of numerical simulation yielding the wave sequence $TC \xrightarrow{c_c} FC \xrightarrow{a} FC \xrightarrow{c_m} OC \xrightarrow{c_f} TC$. Initial conditions (left) and simulation time 9000 (right).

5. $TC \xrightarrow{c_c} FC \xrightarrow{a} FC \xrightarrow{b} FC \xrightarrow{c_f} TC$ wave sequence demonstrates a temperature-controlled to fuel-controlled stable counterflow combustion wave and fuel-controlled to temperature-controlled stable fast combustion wave. Between these combustion waves, there are contact waves of velocities a and b . See Figure 12.

5. Traveling wave equation and its equilibria

In this section, we reduce the system (2.1)–(2.3) to two dimensions as in [17]. We use the moving coordinate $\xi = x - ct$ with $c < 0$. After setting $v_1 = \dot{\theta} = \partial_\xi \theta$, we obtain the system

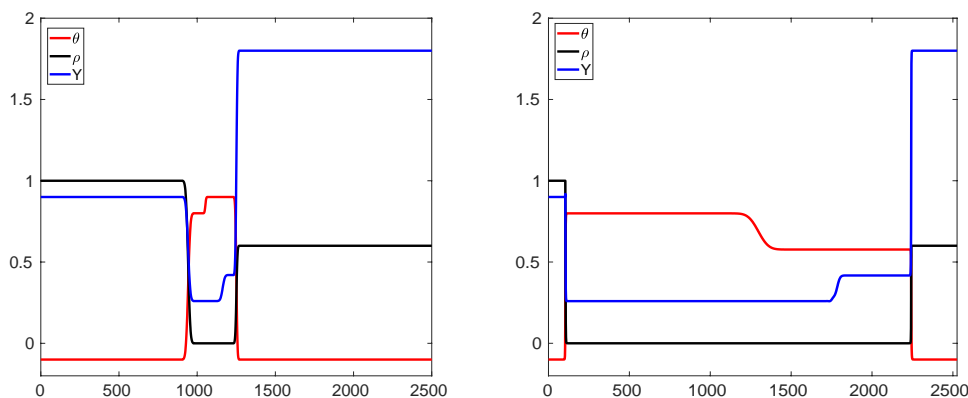

Figure 12. Result of numerical simulation yielding the wave sequence $TC \xrightarrow{c^c} FC \xrightarrow{a} FC \xrightarrow{b} FC \xrightarrow{c^f} TC$. Initial conditions (left) and simulation time 12,000 (right).

$$\dot{\theta} = v_1, \tag{5.1}$$

$$\dot{v}_1 = (a - c)v_1 - \rho Y \Phi(\theta), \tag{5.2}$$

$$w_1 = (c - a)\theta + v_1 + c\rho, \tag{5.3}$$

$$w_2 = (c - b)Y - c\rho, \tag{5.4}$$

where w_1 and w_2 are constants. In (5.1)–(5.2), we substitute for v_1 using (5.3) and for Y using (5.4). We obtain the reduced traveling wave system

$$\dot{\theta} = (a - c)\theta - c\rho + w_1, \tag{5.5}$$

$$\dot{\rho} = \frac{c\rho + w_2}{c(c - b)}\rho\Phi(\theta), \tag{5.6}$$

where (w_1, w_2) is a vector of parameters.

The linearization of (5.5)–(5.6) at a point (θ, ρ) has the matrix

$$\begin{pmatrix} a - c & -c \\ \frac{c\rho + w_2}{c(c - b)}\rho\Phi'(\theta) & \frac{2c\rho + w_2}{c(c - b)}\Phi(\theta) \end{pmatrix}. \tag{5.7}$$

If (θ, ρ) is in TC , (5.7) becomes

$$\begin{pmatrix} a - c & -c \\ 0 & 0 \end{pmatrix}. \tag{5.8}$$

Proposition 5.1 *If an equilibrium of (5.5)–(5.6) is in TC , then one eigenvalue is $a - c$, with eigenvector $(1, 0)$; the other eigenvalue is 0 with eigenvector $(c, a - c)$.*

If (θ, ρ) is in FC or $FC \cap OC$, (5.7) becomes

$$\begin{pmatrix} a - c & -c \\ 0 & \frac{w_2}{c(c - b)}\Phi(\theta) \end{pmatrix}. \tag{5.9}$$

In FC , $Y > 0$ and $\rho = 0$, so $w_2 = (c - b)Y - c\rho = (c - b)Y$ is negative. In $FC \cap OC$, $Y = 0$ and $\rho = 0$, so $w_2 = 0$. Therefore:

Proposition 5.2 *If an equilibrium of (5.5)–(5.6) is in FC or $FC \cap OC$, then one eigenvalue is $a - c$, with eigenvector $(1, 0)$. This eigenvector points along the invariant line $\rho = 0$. The other eigenvalue is negative if $Y > 0$ and is 0 if $Y = 0$.*

If $(\theta, \rho) \in OC$, (5.7) becomes

$$\begin{pmatrix} a - c & -c \\ 0 & \frac{w_2}{c(b - c)}\Phi(\theta) \end{pmatrix}. \quad (5.10)$$

In OC , $Y = 0$ and $\rho > 0$, so $c\rho + w_2 = 0$ and $w_2 > 0$. Therefore:

Proposition 5.3 *If an equilibrium of (5.5)–(5.6) is in OC , then one eigenvalue is $a - c$, with eigenvector $(1, 0)$. This eigenvector points along the invariant line $\rho = -w_2/c$, which corresponds to $Y = 0$. The other eigenvalue is negative.*

In [4], the phase plane analysis was applied to the system (5.5)–(5.6) to prove the existence of counterflow traveling waves.

6. Conclusion

In this paper, we studied traveling waves that occur in a counterflow combustion model. We identified all possible wave sequences by including the counterflow case. Also, contact discontinuities were discussed. Then numerical simulations were presented to show that the wave sequences, including counterflow combustion waves, actually occur. Nonlinear Crank-Nicolson implicit finite difference scheme and Newton’s method were applied to the counterflow combustion system for investigating the simulations. Therefore, we generalized the previous work by including the negative combustion wave speed and completed the diagram of wave sequences.

References

- [1] Akkutlu IY, Yortsos YC. The dynamics of in-situ combustion fronts in porous media. *Combustion and Flame* 2003; 134: 229-247.
- [2] Aldushin AP, Rumanov IE, Matkowsky BJ. Maximal energy accumulation in a superadiabatic filtration combustion wave. *Combustion and Flame* 1999; 118: 76-90.
- [3] Aldushin AP, Seflyarsky BS. Propagation of exothermic reaction in a porous-medium during gas blowing. *Soviet Physics Doklady* 1978; 23: 483-485.
- [4] Barlas G. Existence of counterflow combustion waves in porous media. MSc, Harran University, Şanlıurfa, Turkey, 2020.
- [5] Bruining J, Mailybaev AA, Marchesin D. Filtration combustion in wet porous medium. *SIAM Journal on Applied Mathematics* 2009; 70: 1157-1177.
- [6] Chapiro G. Gas-Solid Combustion in Insulated Porous Media. PhD, IMPA, 2009.
- [7] Chapiro G, Mailybaev AA, Souza AJ, Marchesin D, Bruining J. Asymptotic approximation of long-time solution for low-temperature filtration combustion. *Computational Geosciences* 2012; 16: 799-808.
- [8] Chapiro G, Marchesin D, Schechter S. Combustion waves and Riemann solutions in light porous foam. *Journal of Hyperbolic Differential Equations* 2014; 11 (02): 295-328.

- [9] Chapiro G, Senos L. Riemann solutions for counterflow combustion in light porous foam. *Computational Applied Mathematics* 2018; 37 (2): 1721-1736.
- [10] Mailybaev AA, Bruining J, Marchesin D. Analysis of in situ combustion of oil with pyrolysis and vaporization. *Combustion and Flame* 2011; 158 (6): 1097-1108.
- [11] Mailybaev AA, Marchesin D, Bruining J. Resonance in low-temperature oxidation waves for porous media. *SIAM Journal on Mathematical Analysis* 2011; 43: 2230-2252.
- [12] Marchesin D, Schechter S. Oxidation heat pulses in two-phase expansive flow in porous media. *Zeitschrift für Angewandte Mathematik und Physik (ZAMP)* 2003; 54 (1): 48-83.
- [13] Mota JCD, Santos MM. An application of the monotone iterative method to a combustion problem in porous media. *Nonlinear Analysis: Real World Applications* 2011; 12 (2): 1192-1201.
- [14] Mota JCD, Schechter S. Combustion fronts in a porous medium with two layers. *Journal of dynamics and differential equations* 2006; 18 (3): 615-665.
- [15] Schechter S, Marchesin D. Geometric singular perturbation analysis of oxidation heat pulses for two-phase flow in porous media. *Bulletin of the Brazilian Mathematical Society* 2001; 32 (3): 237-270.
- [16] Schult DA, Matkowsky BJ, Volpert VA, Fernandez-Pello AC. Forced forward smolder combustion. *Combustion and Flame* 1996; 104 (1-2): 1-26.
- [17] Ozbag F, Chapiro G, Schechter S. Traveling Waves In a Simplified Gas-Solid Combustion Model In Porous Media. *Advances in Differential Equations* 2018; 23 (5-6): 409-454.
- [18] Ozbag F. Stability Analysis of Combustion Waves in Porous Media. PhD, NCSU, 2016.
- [19] Wahle C, Matkowsky B, Aldushin A. Effects of gas-solid nonequilibrium in filtration combustion. *Combustion Science and Technology* 2003; 175: 1389-1499.