

1-1-1999

The Effects of Chemicals for Using the Bleaching of the Wood Surfaces on the Layer Hardness of Varnish

BURHANETTİN UYSAL

MUSA ATAR

AYHAN ÖZÇİFÇİ

Follow this and additional works at: <https://journals.tubitak.gov.tr/agriculture>



Part of the [Agriculture Commons](#), and the [Forest Sciences Commons](#)

Recommended Citation

UYSAL, BURHANETTİN; ATAR, MUSA; and ÖZÇİFÇİ, AYHAN (1999) "The Effects of Chemicals for Using the Bleaching of the Wood Surfaces on the Layer Hardness of Varnish," *Turkish Journal of Agriculture and Forestry*. Vol. 23: No. 4, Article 12. Available at: <https://journals.tubitak.gov.tr/agriculture/vol23/iss4/12>

This Article is brought to you for free and open access by TÜBİTAK Academic Journals. It has been accepted for inclusion in Turkish Journal of Agriculture and Forestry by an authorized editor of TÜBİTAK Academic Journals. For more information, please contact academic.publications@tubitak.gov.tr.

The Effects of Chemicals for Using the Bleaching of the Wood Surfaces on the Layer Hardness of Varnish

Burhanettin UYSAL

Yüzüncü Yıl Üniv. Van Professional College,
Furniture and Decoration Department, 65080, Van-TURKEY
Musa ATAR, Ayhan ÖZÇİFÇİ

Gazi Üniv. Faculty of Technical Education, Furniture and Decoration Department, Ankara-TURKEY

Received: 15.06.1998

Abstract: The objective of this research was to determine the effects of sodium hydroxide + hydrogen peroxide, sodium hydroxide + calcium hydroxide + hydrogen peroxide, hypochlorite and hydrochloric acid applied on the scotch pine (*Pinus sylvestris L.*), oriental beech (*Fagus orientalis Lipsky*), ash wood (*Fraxinus excelsior L.*) and oak (*Quercus petraea Mattu Liebl.*) on the layer hardness of acrylic, synthetic, polyurethane and acid catalyzed varnish.

Results indicated that in the natural varnishing effects of wood species on the layer hardness of varnish are unimportant but the effects of varnish types are important. In the varnishing, after bleaching the wood types, bleaching chemicals and their concentration and varnish kinds effected the layer hardness of varnish.

Key Words: Bleaching on the wood, bleaching methods, sodium hydroxide, hydrogen peroxide, calcium peroxide, hypochlorite and hydrochloric acid and varnish.

Ağaç Yüzeylerinde Renk Açmada Kullanılan Kimyasalların Vernik Katman Sertliğine Etkileri

Özet: Bu araştırmada, sarıçam (*Pinus sylvestris L.*), Doğu kayını (*Fagus orientalis Lipsky*), dişbudak (*Fraxinus excelsior L.*) ve sapsız meşe (*Quercus petraea Mattu Liebl.*) üzerinde, sodyum hidroksit + hidrojen peroksit, sodyum hidroksit + kalsiyum hidroksit + hidrojen peroksit, hipoklorit ve hidroklorik asitle renk açma işlemi yapılmıştır. Daha sonra ağaç örneklerin yüzeylerinde akrilik, sentetik, poliüretan ve asit katalizörlü vernikler uygulanarak renk açma kimyasallarının vernik katmanlarının sertliğine etkileri araştırılmıştır.

Deneyler sonucunda; doğal verniklemede, ağaç türünün vernik sertliğine etkisinin önemsiz, vernik türünün etkisinin önemli olduğu, renk açma işleminden sonra yapılan verniklemede ise vernik sertliğine ağaç türünün, renk açmada kullanılan kimyasal türü ve konsantrasyonunun ve vernik türünün etkili olduğu belirlenmiştir.

Anahtar Sözcükler: Ağaçta renk açma, renk açıcılar, renk açma metotları, sodyum hidroksit, hidrojen peroksit, kalsiyum hidroksit,

Introduction

Each of wood species has its own variation in colour, texture and grain pattern. Some cuts of solid wood and flitches of veneer are lighter or darker than others. To arrive at a furniture colour, the choice is generally limited to a colour equal to or darker than the natural colour of the wood. The only way to overcome this darkening is to bleach the wood or use a bleaching toner on the wood before finishing (1).

There are two reasons in the discoloration of wood. One of them, it consists of injuring, drying of branches, disease and etc. in live trees(2). The second one is oxidation, iron stains, fungi discoloration and chemical stains occurred on the wood cut from trees. This kind of discoloration degrades the quality of wood material(3).

In the wooden furniture the colour is as important as size and form. The colour of wooden furniture is to be suitable with carpet, curtain, textile and covering of wall, ceiling and floor used in interior decoration. The colour of natural wood usually doesn't meet this kind of need, for this reason, wooden furniture might be bleached or painted(4).

Bleaching is the removing of the colour pigments in structure of wood by various bleaching chemicals and bleaching systems(5).

The aims of bleaching on the wood surface before finishing are listed as follows(6):

-To obtain more uniform colour or remove dark streaks within a panel and other assembled parts,

- To obtain lighter colours and retain all grain character,

- To control colour and improve the salability,
- To upgrade materials or make more “of “ coloured wood useable and upgrade the final product,
- To use several closely related species, such as several oaks or several ashes or multiple species of wood if needed,
- To make it easier to control colour from one batch or cutting of furniture to another batch and also make it possible to have multiplant production of the same pieces and keep on acceptable colour range,
- To obtain better colour stability and decrease the probability of fading or a colour changing due to the chemical nature of some woods,
- To aid bleached woods such as oak and walnut to perform better in light exposure especially when chemical filtering agents (ultraviolet light exposure absorbents) are combined in the finishing system,
- To obtain controlled surface characteristics and properties. This implies good quality and long lasting finishes.

Besides, specialty bleaches are available for many uses including removal of iron stains, mineral streaks, fungi discoloration and chemical stains. In summary, furniture is bleached to bring out character and get lighter, brighter clearer finishes.

After bleaching, deposits of bleaching chemicals may remain on the surface of wood. If the deposits aren't neutralized they can effect the subsequent finish coats. For this reason after bleaching the surface of wood is neutralized and sanded to remove raised grain. This sanding also removes deposits of bleaching chemicals from surface of wood but the bleached surface should be sanded slightly otherwise unbleached parts may occur(7).

Natural wood and uncoated wood materials are spoiled in a short time because of the external effects. The chemicals which are used in bleaching of wood as they aren't protective layer, they can't protect wood materials against external effects. For this reason, bleached wood surfaces should be covered with materials

which can make protective layer. Recently the varnish which is prepared for wooden furniture and make protective layer is prepared in various structural peculiarities and its both layer peculiarities and applying methods are differed(8).

Introduction

Materials

As wood materials, the scotch pine (*Pinus sylvestris* L), oriental beech (*Fagus orientalis* Lipsky), ash wood (*Fraxinus excelsior* L.) and oak (*Quercus petraea* Mattu Liebl.) were used. The wood samples were chosen randomly from timber merchant of Ankara.

As bleaching chemicals, sodium hydroxide (NaOH), hydrogen peroxide (H₂O₂), calcium hydroxide (Ca (OH)₂), hypochlorite acid (HClO) and hydrochloric acid (HCl) were used. Acetic acid (CH₃ COOH) was used for neutralization. As varnish, acrylic, synthetic, polyurethane and acid catalyst varnish were used.

Preparing of Test Samples

Test samples were prepared according to ASTM-D 358(9). Chosen timber were climatized on the condition of 20 °C ± 2 °C and % 65 ± 3 relative humidity approximately three weeks. After that, samples (150x100x12± 1mm) were cut from climatized timbers. Five samples were cut from each wood species for four chemicals. 5x4=20 samples for the scotch pine, 5x4=20 samples for the oriental beech, 5x4=20 samples for oak, 5x4=20 samples for the ash wood and 5x4=20 samples for the control samples. A total of 100 samples were cut. After sanding process the test samples were ready for bleaching.

All solutions were applied on the samples with a natural sponge. Because it takes in more solution and distributes equally on the surfaces. Solutions were firstly applied parallel to grain then against the grain. At the end again parallel to grain. After waiting one hour for chemical absorption by wood samples extra solution was sponged. The samples were conditioned for a day in conditioning room for improving of the effects of

Table 1. Preparing of the Used Solutions in Bleaching.

Solution	Solvent	Temperature(C°)	Chemicals
I	Pure water	20	50g/l NaOH and % 50 H ₂ O ₂
II	Pure water	20	50g/l NaOH, 50g/l Ca(OH) ₂ and % 50 H ₂ O ₂
III	Pure water	20	% 50 HClO.
IV	Pure water	20	% 18 HCl.

bleaching. Then the samples which were applied I. and II. solutions were neutralized with % 15 CH_3COOH solution and all the samples were washed with pure water. After neutralization, all the samples were dried on the condition of $20^\circ\text{C} \pm 2^\circ\text{C}$ and % 65 ± 3 relative humidity until % 12 moisture content.

Preparing, Applying and Drying of Varnish

After bleaching the test samples were varnished according to the ASTM-D 3023(10). Synthetic varnish was applied a bristle brush. The others(acrylic, polyurethane and acid catalyst) were applied with a pistol which was used according to approval of producer firm. Firstly, the filling varnish was applied and dried then

sanded with 220 numbered sandpaper. After that the last layer was applied. The quantity of applied varnish was then determined with a balance which has 0.01 sensitiveness.

Determination of Surface Hardness and Pandulum Hardness Measurement Device

The most indicator of varnish latsness to the external effects is the layer hardness of varnish. After bleaching the layer hardness of samples which were varnished, were determined with a pendulum hardness measurement device (given in figure 1).

1. Sample press hand
2. Sample catch platform
3. Sample stop
4. Sample
5. Pandulum
6. Persoz beginning point
7. Köning beginning point
8. Photocell
9. Scale
10. Releasing pin
11. Automatic counter
12. Food
13. Releasing wire
14. Protective

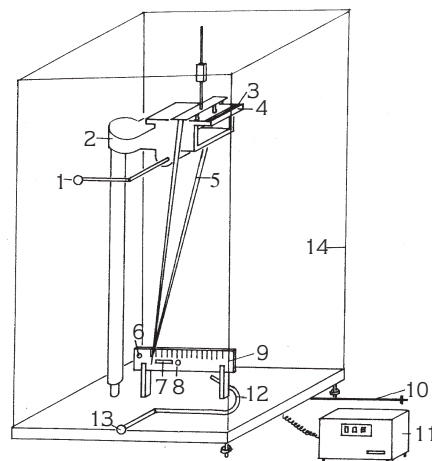

Figure 1. Pandulum Hardness Measurement Device(11).

The device determines the layer hardness according to swing of pandulum which has two marbles consist of 63 ± 3.3 HRC hardness and 5 ± 0.0005 mm diameters on the sample surfaces. According to the principle of hardness determination, the amount of swing increases directly proportional to hardness of the surfaces.

Before the test, the device had been calibrated (140 seconds/100 swels) on the calibration glass or on the polished iron plate. Each passing of pandulum in front of photocell was calculated as one swing(12).

Statistical Analyses

The obtain data from experiments were analysed in the MSTATC Packet Program. When the effects of factorial variance analyses were found important in $P < 0.01$ and 0.05 , the value of LSD (least significant difference) were used for comparison.

Results

Varnishing of Natural Wood

The average values which were calculated according to the obtained data from the result of the test are given as fallow.

Table 2. The Result of Variance Analyses Connected with Wood Material, Chemical and Varnish

Source	Degrees of Freedom	Sum of squares	Mean square	F value	Prob
Material	3	2174.833	724.944	31.4552	0.0000
Varnish	3	11945.762	3981.931	172.7753	0.0000
Material+varnish	9	3857.375	428.597	18.5968	0.0000
Chemical	3	392.708	130.903	5.6789	0.0011
Material+chemical	9	827.292	91.921	3.9884	0.0002
Varnish+chemical	9	1024.000	113.778	4.9368	0.0000
Mater+varnis+chemi	27	1906.667	70.617	3.0641	0.0000
Error	128	2950.000	23.047	-	-
Total	191	25078.667	-	-	-

Coefficient of variation (% 15.53), given as a automatic by MSTATC packet programme Statistically, all of the considered sources were found to be significant.

Table 3. To Arrange in a Row the Hardness of Wood Materials

Materials	Average	LSD
Oriental beech	25.38	C
Scotch pine	31.75	B
Ash wood	34.46	A
Oak	32.08	B

LSD value: 1.939, α :0.05

Table 3. shows that the hardest value was given by the ash wood as 34.46, by the oak as 32.08, by the scotch pine as 31.75 and by the oriental beech as 25.38. Both scotch pine and oak are in the hardness homogenous group.

According to the table 4. the hardest layer is given by polyurethane, the second is acid catalyzed and the third is

Table 4. To Arrange in a Row the Hardness of Varnish.

Varnish	Average	LSD
Acrylic	25.23	C
Synthetic	25.06	C
Polyurethane	44.29	A
Acid catalyzed	29.08	B

LSD value: 1.939, α :0.05

acrylic and synthetic. Because the polyurethane and acid catalyzed varnish have artificial resins in their structure so it is possible to adjust the hardness of varnish. But the softening effect of dryable oils which were used in the production of synthetic varnish may be cause of decreasing the hardness of varnish.

Table 5. and figure 2. show that while the hardest layer is given by polyurethane on the ash wood, the least

Table 5. The Layer Hardness of Varnish in Natural Varnishing

Mat/Var.	Acrylic	LSD	Synthetic	LSD	Polyurethan	LSD	Acid catalized	LSD
Beech	18.75	L	22.17	IJ	37.50	D	23.08	IJ
Scotch pine	19.67	KL	21.08	JK	45.00	B	41.25	C
Ash wood	32.58	E	30.92	EF	50.33	A	24.00	I
Oak	29.92	FG	26.08	H	44.33	B	28.00	GH

hardness is given by acrylic on the beech wood. As the polyurethane varnish gave the hardest layer on the ash wood as 50.33, on the scotch pine as 45, on the oak as 44.33, the acid catalyzed varnish gave the hardest layer value on the scotch pine as 41.25. All the varnish types gave their the hardest layer value on the ash wood except the acid catalyzed varnish.

The Hardness of Varnish on the Bleached Surfaces

Tablo 6 and Figure 3 show that on the bleached beech samples with HClO solution polyurethane gave the hardest layer and on the bleached beech with NaOH+H₂O₂ solution synthetic gave the least hardness.

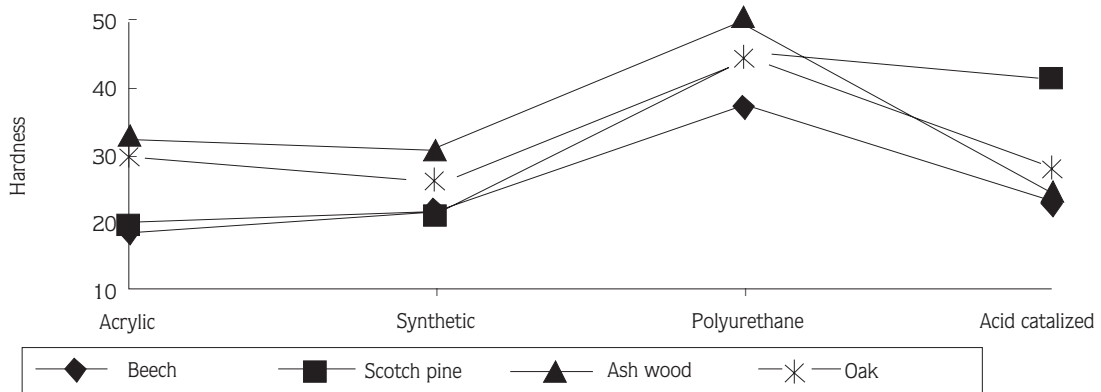

Figure 2. The Layer Hardness of Varnish in Natural Varnishing

Table 6. The Layer Hardness of Varnish on the Bleached Beech Samples.

Varnish	NaOH+H ₂ O ₂	LSD	NaOH+Ca(OH)+H ₂ O ₂	LSD	HClO	LSD	HCl	LSD
Acrylic	17.67	I	18.67	HI	19.33	GHI	19.33	GHI
Synthetic	14.00	J	23.00	F	25.33	E	26.33	E
Polyuretha	28.67	D	38.00	C	42.67	A	40.67	B
Acid catali	20.00	GH	21.33	FG	30.00	D	21.00	FG

LSD value: 1.939

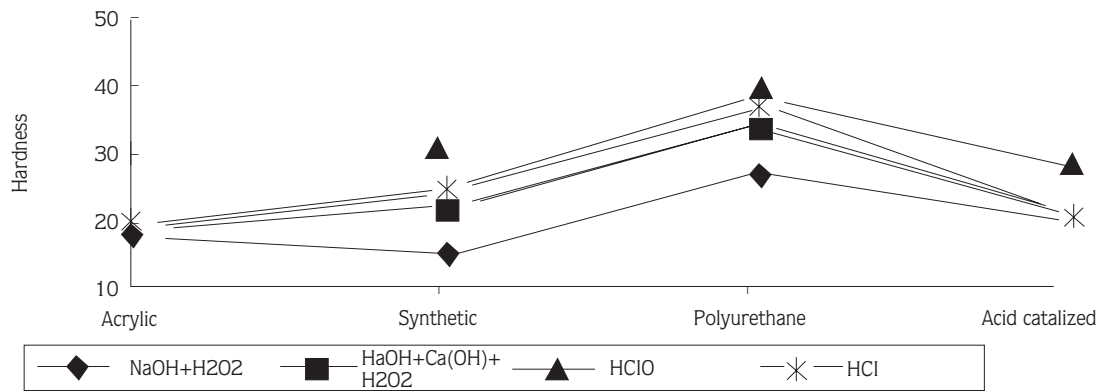

Figure 3. The Layer Hardness of Varnish on the Bleached Beech Samples.

Table 7. The Layer Hardness of Varnish on the Bleached Scotch Pine Samples.

Varnish	NaOH+H ₂ O ₂	LSD	NaOH+Ca(OH)+H ₂ O ₂	LSD	HClO	LSD	HCl	LSD
Acrylic	17.33	H	20.33	FG	18.67	GH	22.33	F
Synthetic	21	F	21.33	F	21.33	F	21	F
Polyureth	39.67	D	47.67	B	45.33	C	47.33	B
Acid catal	50.67	A	34.67	E	43.67	C	36	E

LSD value: 1.939

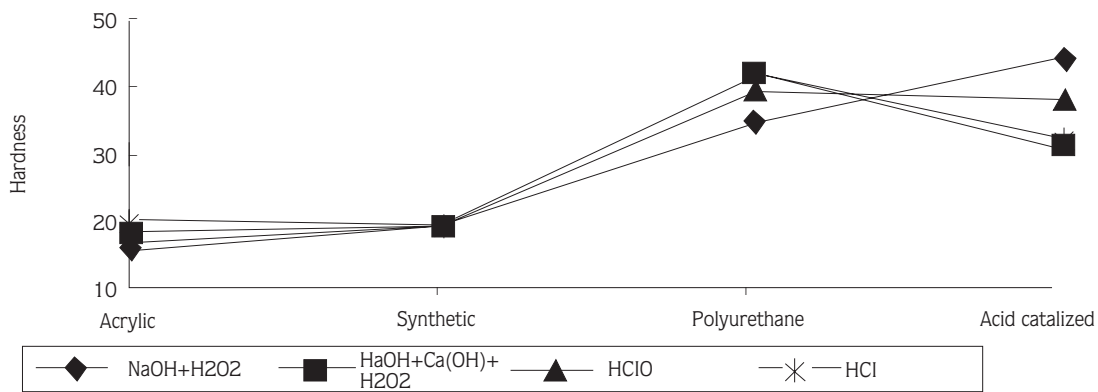

Figure 4. The Layer Hardness of Varnish on the Bleached Scotch Pine Samples.

Table 8. The Layer Hardness of Varnish on the Bleached Ash Wood Samples.

Varnish	NaOH+H ₂ O ₂	LSD	NaOH+Ca(OH)+H ₂ O ₂	LSD	HClO	LSD	HCl	LSD
Acrylic	45.33	C	24.67	G	34.33	D	22.33	F
Synthetic	21	F	30	EF	28.67	F	34	D
Polyureth	50	B	50	B	50	B	52	A
Acid catal	25.67	G	17.33	I	33.33	D	19.67	H

LSD value: 1.939

Table 7 and figure 4 show that while the acid catalyzed varnish gives the hardest layer on the bleached scotch pine with NaOH+H₂O₂ solution used on scotch pine.

Table 8 and figure 5 show that the polyurethane varnish gives the hardest layer on bleached ash wood samples with all chemical solutions but acid catalyzed

Table 9. The Layer Hardness of Varnish on the Bleached Oak Samples.

Varnish	NaOH+H ₂ O ₂	LSD	NaOH+Ca(OH)+H ₂ O ₂	LSD	HClO	LSD	HCl	LSD
Acrylic	19	I	37.33	D	41.33	C	22	H
Synthetic	25.67	FG	27.67	F	25.67	FG	25.33	G
Polyureth	46.33	A	43	BC	43.33	BC	44.67	AB
Acid catal	31.33	E	22	H	32	E	26.67	FG

LSD value: 1.939

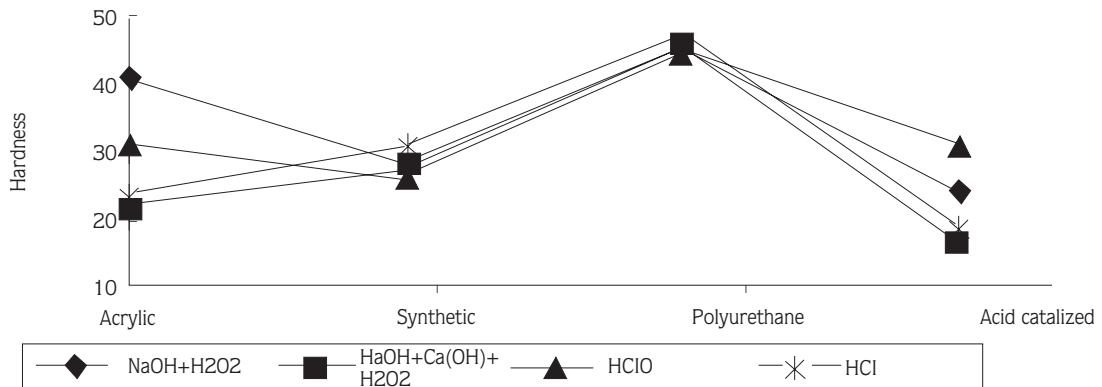

Figure 5. The Layer Hardness of Varnish on the Bleached Ash Wood Samples.

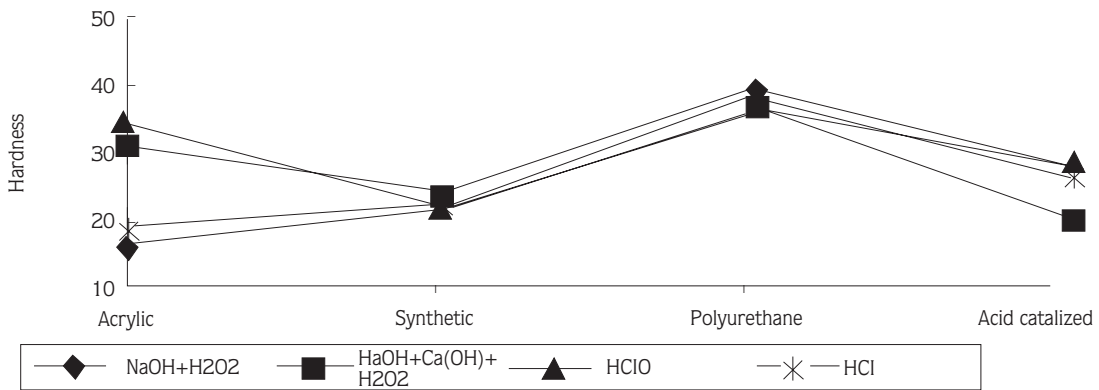

Figure 6. The Layer Hardness of Varnish on the Bleached Oak Samples.

varnish gives the least hardness on the ash wood which was bleached with $\text{NaOH}+\text{Ca}(\text{OH})_2+\text{H}_2\text{O}_2$ solution.

Table 9 figure 6 show that the polyurethane varnish gives the hardest layer on bleached oak with $\text{NaOH}+\text{H}_2\text{O}_2$ solution but the acrylic varnish gives the least hardness on bleached oak with same solution.

Conclusions

According to the datas obtained from the test the following results can be discussed.

1. The ash wood gave the highest hardness values and the beech gave the lowest value.

2. When the varnish were arranged in a row; the highest value was given by polyurethane varnish and the lowest by acrylic and synthetic varnish(8, 13). The

softening effect of dryable oils which are used in the production of the synthetic varnish may be to cause of achieving the lowest hardness value of all.

3. In natural varnishing, the polyurethane varnish gave the highest hardness value. Therefore it can be said that in natural varnishing, the effects of wood species on the layer hardness of varnish are unimportant but the effects of varnish are important.

4. On the beech wood which was bleached with HClO solution, the polyurethane varnish gave the highest hardness value but the synthetic varnish gave the lowest hardness value with $\text{NaOH}+\text{H}_2\text{O}_2$ solution.

5. On the scotch pine which was bleached with $\text{NaOH}+\text{H}_2\text{O}_2$ solution the acid catalyzed varnish gave the hardest layer but the acrylic varnish gave the lowest hardness with the same solution.

6. On the ash wood, the polyurethane varnish gave the hardest layer with all the used solutions, but the acid catalyzed varnish gave the lowest hardness value with $\text{NaOH}+\text{Ca}(\text{OH})_2+\text{H}_2\text{O}_2$ solution.

7. On the oak wood which was bleached with $\text{NaOH}+\text{H}_2\text{O}_2$, the polyurethane gave the highest hardness

value but the acrylic varnish gave the lowest hardness value with the same solution.

Consequently, it can be said varnishing after bleaching the wood species, bleaching chemicals and their concentrations and varnish types effected the layer hardness of varnish.

References

1. Gerard, M. C.. "Furniture Finishing Processes and Systems", Finishing Eastern Hardwoods, p 40-44, Madison-USA, 1983.
2. Shigo, A. L., and Hillis, W. E., Heartwood, Discoloured Wood and Microorganisms in Living Trees, Ann. Rev. Phytopathol, v 11, p 197-222, 1973,
3. Bauch, J., Discoloration in the Wood of Living and Cut Trees, IAWA Bulletin, n.s. 92-97, Netherlands.
4. Çakıcıer, N., Ahşap Yüzeylerinde Kullanılan Verniklerin Su ile Eritilen Önemli Ağaç Boyaları ile Boyanmış Yüzeylerde Yaptığı Renk Değişiklikleri, Endüstriyel Teknoloji Dergisi, v 1, 2, p 34-40, Ankara, 1996.
5. Ejechi, B. O., and Obuekwe, C. O., Microchemical Studies of Wood Degradation by Brown Rot and White Rot Fungi in Two Tropical Timbers, International Biodeterioration Biodegradation, v.38, n.2, p119-122, Nigeria, 1996.
6. Edwin, P. B, and Carter, M., Wood "Bleaches and Bleaching Methods", Finishing Eastern Hardwoods, p.29.39, Madison-USA, 1983.
7. Engler, N., The Workshop Companion Finishing Techniques for Better Woodworking, p 61, Rodale Press, Emmaus, Pennsylvania, 1989..
8. Sönmez, A., Ağaçtan Yapılmış Mobilya Üstyüzeylerinde Kullanılan Verniklerin Önemli Mekanik, Fiziksel ve Kimyasal Etkilere Karşı Dayanıklıkları, G. Ü. Fen Bil. Enst., Doktora Tezi, Ankara, 1989.
9. ASTM-D 358., Wood to be Used as Panels in Weathering Tests of Coatings, 1983.
10. ASTM-D 3023., Determination of Resistance of Factory Applied Coatings on Wood Products of Stain and Reagents, 1981 .
11. Erichsen, Operating Instructions, 299/300/E
12. ASTM-D 4366-84., Hardness of organic coatings by pendulum damping test.
13. Budakçı, M., Ahşap Verniklerde Katman Kalınlığının Sertlik, Parlaklık ve Yüzeye Yapışma Mukavemetine Etkileri, G. Ü. Fen Bil. Enst., Yüksek Lisans Tezi, Ankara, 1997.