

1-1-2017

## Using fuzzy logic for diagnosis and classification of spasticity

VEYSEL ALCAN

MEHMET RAHMİ CANAL

MURAT ZİNNUROĞLU

Follow this and additional works at: <https://journals.tubitak.gov.tr/medical>



Part of the [Medical Sciences Commons](#)

---

### Recommended Citation

ALCAN, VEYSEL; CANAL, MEHMET RAHMİ; and ZİNNUROĞLU, MURAT (2017) "Using fuzzy logic for diagnosis and classification of spasticity," *Turkish Journal of Medical Sciences*: Vol. 47: No. 1, Article 22. <https://doi.org/10.3906/sag-1512-65>

Available at: <https://journals.tubitak.gov.tr/medical/vol47/iss1/22>

This Article is brought to you for free and open access by TÜBİTAK Academic Journals. It has been accepted for inclusion in Turkish Journal of Medical Sciences by an authorized editor of TÜBİTAK Academic Journals. For more information, please contact [academic.publications@tubitak.gov.tr](mailto:academic.publications@tubitak.gov.tr).

## Using fuzzy logic for diagnosis and classification of spasticity

Veysel ALCAN<sup>1\*</sup>, Mehmet Rahmi CANAL<sup>2</sup>, Murat ZİNNUROĞLU<sup>3</sup>

<sup>1</sup>Department of Electricity-Electronics Technology, Ministry of National Education, Ankara, Turkey

<sup>2</sup>Department of Computer Engineering, Faculty of Technology, Gazi University, Ankara, Turkey

<sup>3</sup>Department of Physical Medicine and Rehabilitation, Faculty of Medicine, Gazi University, Ankara, Turkey

Received: 11.12.2015 • Accepted/Published Online: 17.05.2016 • Final Version: 27.02.2017

**Background/aim:** Spasticity is generally defined as a sensory-motor control disorder. However, there is no pathophysiological mechanism or appropriate measurement and evaluation standards that can explain all aspects of a possible spasticity occurrence. The objective of this study is to develop a fuzzy logic classifier (FLC) diagnosis system, in which a quantitative evaluation is performed by surface electromyography (EMG), and investigate underlying pathophysiological mechanisms of spasticity.

**Materials and methods:** Surface EMG signals recorded from the tibialis anterior and medial gastrocnemius muscles of hemiplegic patients with spasticity and a healthy control group were analyzed in standing, resting, dorsal flexion, and plantar flexion positions. The signals were processed with different methods: by using their amplitudes in the time domain, by applying short-time Fourier transform, and by applying wavelet transform. A Mamdani-type multiple-input, single-output FLC with 64 rules was developed to analyze EMG signals.

**Results:** The wavelet transform provided better positive findings among all three methods used in this study. The FLC test results showed that the test was 100% sensitive to identify spasticity with 95.8% accuracy and 93.8% specificity.

**Conclusion:** A FLC was successfully designed to detect and identify spasticity in spite of existing measurement difficulties in its nature.

**Key words:** Spasticity, surface electromyography, fuzzy logic, wavelet transform

### 1. Introduction

Spasticity is a common sensory-motor control disorder characterized by increased velocity-dependent stretch reflex responses resulting from upper motor neuron (UMN) lesions (1). Spasticity is frequently observed in cases such as spinal cord injury, multiple sclerosis, traumatic brain damage, cerebral palsy, and stroke, which can be accompanied by cerebral and spinal pathology that is dispersed or regional (2). The pathophysiology of spasticity is complicated and it is rather difficult to understand the underlying mechanism since it is necessary to know the pathophysiological mechanism that would differentiate the UMN syndrome from other symptoms (3,4). Therefore, spasticity is a disorder that is both insufficiently defined and measured (5). There are three major approaches, clinical, neurophysiological, and biomechanical, for assessing spasticity.

The Ashworth Scale (AS) and the modified Ashworth Scale (MAS) are the most commonly used clinical measures of spasticity. The validity, reliability, and sensitivity of the clinical scales, which are subject to interpretation

and generally intensified upon passive movement resistance, are debatable (6–8). As a consequence, many studies have been conducted using biomechanical and electrophysiological measurements with the objective of evaluating spasticity, and the obtained results have been used to make correlations with the clinical scales (8–14). Surface electromyography (EMG) has been commonly used in electrophysiological measurements of spasticity (14–16). However, parameters extracted from surface EMG have been generally obtained from analysis by using only the time domain in previous studies, and results were generally based on correlations with the clinical scales rather than using stand-alone surface EMG as well as considering causality. Due to the fact that surface EMG signals are nonstationary and random signals, some pathological data might not be discriminated in the time axis. Therefore, it is possible to utilize the short-time Fourier transform (STFT) and the wavelet transform (WT) methods from the time and the frequency components of the signals found in the pathological symptoms (17,18).

\* Correspondence: [alcanveysel@gmail.com](mailto:alcanveysel@gmail.com)

On the other hand, using statistical methods, the classifications in the diagnosis of spasticity, which has multifactorial and complicated causal relationships, could be insufficient in explaining the complicated relations in this disease. Instead of that, intelligent systems, especially rule-based or knowledge-based systems, are able to overcome these insufficiencies (19,20). A fuzzy logic (FL) system facilitates solving problems in a given field or application by drawing inference from a knowledge base developed from human expertise.

In this study, it was aimed to analyze with different methods the surface EMG signals obtained in different positions from hemiplegic patients with spasticity and in a healthy control group for the quantitative measurement of spasticity and to realize the diagnosis of spasticity with a fuzzy logic classifier (FLC).

## 2. Materials and methods

### 2.1. Groups

Sixteen healthy volunteer subjects (age:  $56.44 \pm 6.5$  years, females/males: 4/12, MAS:  $0 \pm 0.00$ ) and 8 patients (age:  $50.88 \pm 15.9$  years, females/males: 2/6, MAS:  $2 \pm 0.93$ ) with spasticity in the plantar flexion direction participated in this study. The inclusion criterion for patients was having spasticity (at least grade 1 by the MAS) in a unilateral lower leg (plantar flexion) due to subacute and chronic cerebrovascular accidents. Being below 18 or above 70 years of age, existence of contractures in the ankle, high grade of spasticity (grade 4 by the MAS), and skin problems (infections, open wounds, etc.) in the regions where the surface electrode would be placed were exclusion criteria. The study protocol was approved by the Gazi University Faculty of Medicine Ethics Committee, and all participants signed consent forms.

### 2.2. Experimental setup and protocol

Basic hardware and equipment were selected and set up in the system, such as the EMG equipment (Nihon Kohden, 8-channel MEB-5508K Neuropack model), connector cables and connectors, bipolar silver surface electrodes that are pregelled circular (diameter: 10 mm) electrodes (solid gel), data terminal card (Advantage PCLD-8710), data collection and control card (Advantage PCI 1710HG data acquisition card), and a user-friendly interface program (21).

The surface electrodes used in the recordings were placed on the right and left legs' tibialis anterior (TA) and medial gastrocnemius (MG) muscles in accordance with the Surface Electromyography for the Non-Invasive Assessment of Muscles protocol (22). The distance between electrodes was 20 mm and the reference electrode was placed over an electrically silent inactive area such as tendon or bone. The electrodes were positioned on the most prominent bulge of the MG muscle and the middle belly of

the TA muscle. The surfaces where the electrodes would be connected were disinfected with a cleaning gel prior to recording. The surface EMGs of the subjects were recorded from the TA and MG muscles in standing, resting, dorsal flexion (DF), and plantar flexion (PF) positions as shown in Figure 1. The surface EMG recordings and the clinical spasticity evaluations were made in the same environment and by the same person. The surface EMG signals were recorded with a single frame length and period of 30 s at the ratio of 10,000 samples (12 bit A/D).

### 2.3. Analysis of surface EMG signals and feature selection

Analyses of the amplitude, STFT, and WT methods as well as preanalyses, including rectification and denoising of raw EMG signals, were all performed with MATLAB (The MathWorks Inc., Natick, MA, USA). One major problem of surface EMG is the occurrence of crosstalk, which could be expected in particular between the MG and TA muscles. The wavelet would interpret a crosstalk signal as an EMG signal originating from the muscle to which the recording channels is attributed. Consequently, in applying wavelets, the problem of crosstalk is reduced compared to other conventional ways of interpreting surface EMG signals. In order to determine and eliminate the existing noise of the components in the contents of the signals in a very efficient manner, a wavelet-denoising method was used (23) to obtain the original signals. Daubechies 22 with 10 levels was selected as the wavelet function. A min-max scaling rule and the soft threshold method were used for denoising. The signal shape after denoising is given in Figure 2. After the denoising process, a MATLAB function was developed for the STFT analysis to perform spectral analysis of the EMG signals. A sample diagram is given in Figure 3. The choice of windowing function was determined as the Welch window since this method was capable of providing good resolution if data length samples were selected optimally. In digital signal processing, the Welch method improved upon the periodogram by addressing the lack of ensemble averaging, which is present in the true power spectral density (PSD) formula. It is a cheap, effective method depending on the application. Eq. (2.1) defines the Welch window:

$$w(n) = 1 - \left( \frac{n - N/2}{N/2} \right)^2 \quad (2.1)$$

for  $n = 0, 1, 2, \dots, N - 1$ , where  $N$  is the length of the window and  $w$  is the window value.

For each time segment of the signal, there is a corresponding spectrum and the totality of these spectra gives a time-frequency distribution known as a spectrogram. Maximum power (Max.pow) is the frequency at which the maximum EMG power occurs. The continuous wavelet transform, discrete wavelet transform, and package

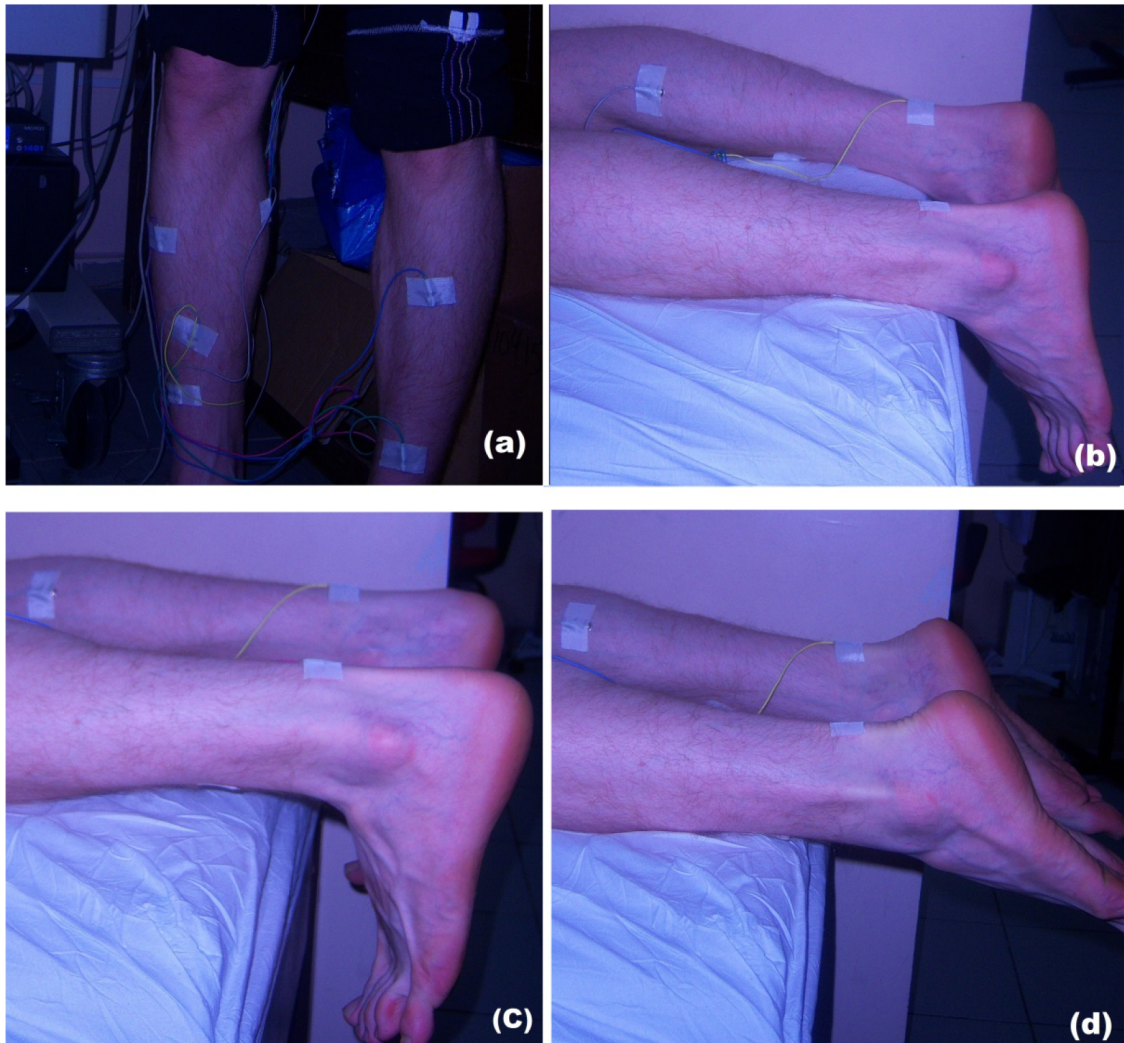

**Figure 1.** Recording of surface EMG: a) standing position; b) resting position; c) DF position; d) PF position

wavelet transform are methods used extensively in the WT analysis. The discrete wavelet transform technique was preferred in this study due to ease of calculations and obtaining the data for signals with as few components as possible in a shorter period of time (24). We used the oldest and best known one, the Mallat (pyramidal) algorithm. In this algorithm two filters, a smoothing and a nonsmoothing one, are constructed from the wavelet coefficients and those filters are recurrently used to obtain data for all the scales. Although one would expect a larger number of features related to these methodologies as well as the different analyzing methodologies, we preferred six parameters obtained from amplitude, STFT, and WT analysis based on common usage in the literature. These parameters are listed in Table 1.

Variables were investigated as to whether or not they supported the hypotheses for the existence of spasticity in order to determine feature selection among six parameters.

Three research hypotheses were studied for the existence of spasticity by comparing the surface EMG parameters of the random sides chosen from the right and left legs of healthy subjects and from the hemiplegic sides of patients. Our first hypothesis was that the surface EMG values that were measured randomly on the sides of healthy subjects in four positions and were measured on the hemiplegic side of the patients affected by spasticity were different from each other, and the surface EMG values measured from TA and MG muscles on the affected sides of the patients with spasticity were more severe than those of healthy subjects due to increased tonus. Our second hypothesis was that the increase in the surface EMG values measured from TA muscles on the affected side in the DF position could not be expected to be like those in healthy subjects. The differences between the measured values from the TA and MG muscles were less than in healthy subjects. Our third hypothesis was that the increase in the surface



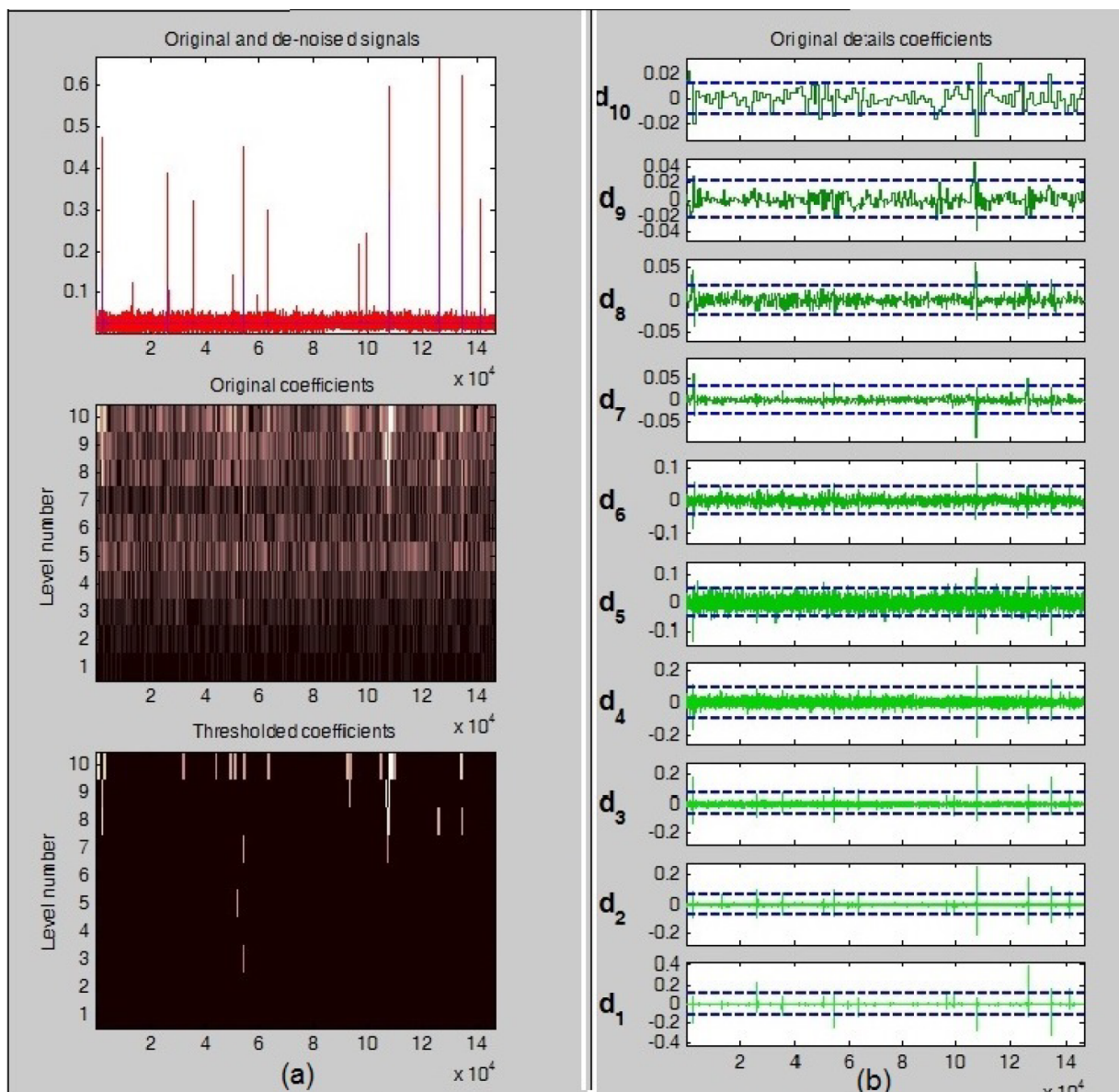

$d_1 \dots d_{10}$  = detail coefficients

**Figure 2.** The denoised signal recorded from a patient: a) original (red) and denoised (navy blue) signals; b) the thresholds for each decomposition level  $d_1 \dots d_{10}$  = detail coefficients.

EMG values for the MG muscles measured on the affected sides of the patients with spasticity in a PF position could not be expected to be like those in healthy subjects. The differences between the measured values from the TA and MG muscles were less than in healthy subjects. Relevant data are provided in Tables 2–5.

#### 2.4. Statistical analysis

The data were analyzed with Shapiro–Wilk test by using SPSS 18 for whether or not the data for the independent variables had a normal distribution and normality with a 5% level of confidence. Nonparametric tests were preferred

since our data set contained less than 30 samples. The comparisons for the hypotheses were conducted with the nonparametric Mann–Whitney U Test with a 5% level of confidence.

#### 2.5. Fuzzy logic classification

Natural evolution of various diseases, complicated causal relationships, the difficulty of understanding medical data, and abstruseness of medical problems require a consistent framework that will be able to overcome the uncertainty and facilitate multiple class memberships that would provide for conjectural/approximate

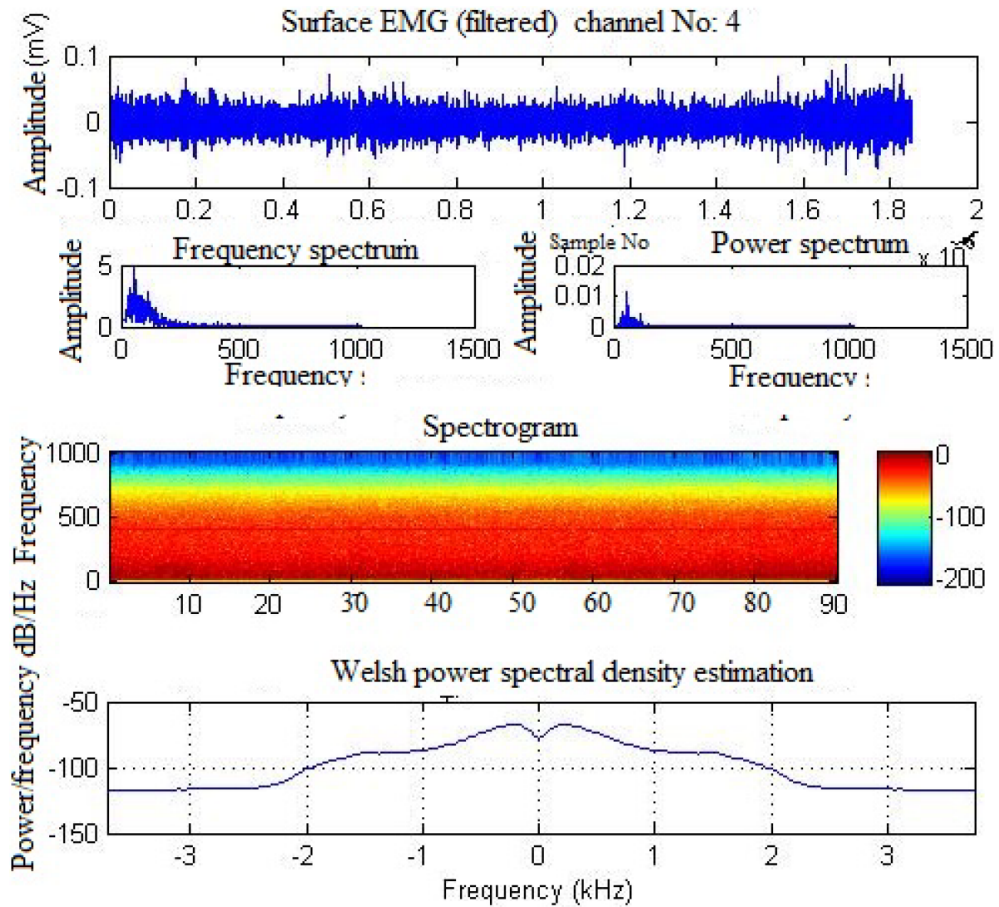

Figure 3. A patient's signal graphs obtained from the STFT analysis.

Table 1. Variables for feature vector.

Abbreviations of variables	Explanations
Mean	Mean value is related to the EMG signal amplitude
Mean.abs	Mean absolute value is related to the EMG signal amplitude
Mean_SD	Standard deviation of mean value is related to the EMG signal amplitude
D_median.abs	10th level detailed coefficient median absolute value is related to wavelet analysis of the EMG signal and obtained by using WT
D_mean.abs	10th level detailed coefficient mean absolute value is related to wavelet analysis of the EMG signal and obtained by using WT
Max.pow	Maximum power value is related to spectrum analysis of the EMG signal and obtained by using STFT

reasoning. FL examines very valuable classical logic in its generalized form and, rather than a definite conclusion, it is an artificial intelligence rule-based form, which uses approximate means of solution and membership functions (25). In this study, a trapezoidal

membership function was selected. The trapezoidal membership function is a special condition of the triangular membership function, which is expressed in the form of four parameters  $\{a_1, a_2, a_3, \text{ and } a_4\}$  as defined in Eq. (2.2).

**Table 2.** The comparison of variables obtained from the affected side of patients and the healthy subjects in standing position.

Position	Muscle	Normal side (healthy)	Hemiplegic side (patient)	P
		Avg $\pm$ SD	Avg $\pm$ SD	
Standing	TA <sub>Mean</sub>	0.0338 $\pm$ 0.025	0.0216 $\pm$ 0.018	0.285
	MG <sub>Mean</sub>	0.0338 $\pm$ 0.026	0.4204 $\pm$ 0.369	0.053
	TA <sub>Mean.abs</sub>	0.0074 $\pm$ 0.003	0.0102 $\pm$ 0.007	0.385
	MG <sub>Mean.abs</sub>	0.0115 $\pm$ 0.005	0.0137 $\pm$ 0.007	0.547
	TA <sub>Mean.SD</sub>	0.0100 $\pm$ 0.005	0.0131 $\pm$ 0.009	0.422
	MG <sub>Mean.SD</sub>	0.0152 $\pm$ 0.007	0.0179 $\pm$ 0.009	0.639
	TA <sub>D_Mdn.abs</sub>	0.0118 $\pm$ 0.015	0.0132 $\pm$ 0.007	0.181
	MG <sub>D_Mdn.abs</sub>	0.0197 $\pm$ 0.014	0.0111 $\pm$ 0.008	0.124
	TA <sub>D_Mean.abs</sub>	0.0148 $\pm$ 0.017	0.0166 $\pm$ 0.009	0.256
	MG <sub>D_Mean.abs</sub>	0.0250 $\pm$ 0.016	0.0153 $\pm$ 0.011	0.124
	TA <sub>Max.pow</sub>	2.9298 $\pm$ 1.485	4.2580 $\pm$ 3.435	0.592
	MG <sub>Max.pow</sub>	4.7066 $\pm$ 2.719	6.3395 $\pm$ 4.430	0.547

TA: Tibialis anterior, MG: medial gastrocnemius, Avg: average, SD: standard deviation.

**Table 3.** The comparison of variables obtained from the affected side of patients and the healthy subjects in resting position.

Position	Muscle	Normal side (healthy)	Hemiplegic side (patient)	P
		Avg $\pm$ SD	Avg $\pm$ SD	
Resting	TA <sub>Mean</sub>	0.0347 $\pm$ 0.038	0.0227 $\pm$ 0.020	0.806
	MG <sub>Mean</sub>	0.0406 $\pm$ 0.045	0.3737 $\pm$ 0.375	0.126
	TA <sub>Mean.abs</sub>	0.0038 $\pm$ 0.002	0.0046 $\pm$ 0.004	0.581
	MG <sub>Mean.abs</sub>	0.0036 $\pm$ 0.001	0.0051 $\pm$ 0.004	0.358
	TA <sub>Mean.SD</sub>	0.0049 $\pm$ 0.002	0.0060 $\pm$ 0.005	0.759
	MG <sub>Mean.SD</sub>	0.0046 $\pm$ 0.002	0.0067 $\pm$ 0.005	0.220
	TA <sub>D_Mdn.abs</sub>	0.0037 $\pm$ 0.004	0.0035 $\pm$ 0.002	0.581
	MG <sub>D_Mdn.abs</sub>	0.0025 $\pm$ 0.000	0.0039 $\pm$ 0.001	0.012
	TA <sub>D_Mean.abs</sub>	0.0045 $\pm$ 0.005	0.0058 $\pm$ 0.006	0.391
	MG <sub>D_Mean.abs</sub>	0.0033 $\pm$ 0.001	0.0060 $\pm$ 0.002	0.014
	TA <sub>Max.pow</sub>	2.2817 $\pm$ 1.280	2.6555 $\pm$ 3.907	0.270
	MG <sub>Max.pow</sub>	2.1610 $\pm$ 0.943	2.8775 $\pm$ 3.805	0.391

TA: Tibialis anterior, MG: medial gastrocnemius, Avg: average, SD: standard deviation.

**Table 4.** The comparison of variables obtained from the affected side of patients and the healthy subjects in DF position.

Position	Muscle	Normal side (healthy)	Hemiplegic side (patient)	P
		Avg $\pm$ SD	Avg $\pm$ SD	
Dorsal flexion	TA <sub>Mean</sub>	0.0791 $\pm$ 0.027	0.0271 $\pm$ 0.025	0.000
	MG <sub>Mean</sub>	0.0431 $\pm$ 0.018	0.3754 $\pm$ 0.375	0.270
	TA <sub>Mean.abs</sub>	0.0492 $\pm$ 0.017	0.0127 $\pm$ 0.013	0.000
	MG <sub>Mean.abs</sub>	0.0179 $\pm$ 0.008	0.0147 $\pm$ 0.017	0.177
	TA <sub>Mean.SD</sub>	0.0645 $\pm$ 0.022	0.0163 $\pm$ 0.017	0.000
	MG <sub>Mean.SD</sub>	0.0231 $\pm$ 0.011	0.0198 $\pm$ 0.023	0.198
	TA <sub>D_Mdn.abs</sub>	0.1110 $\pm$ 0.051	0.0150 $\pm$ 0.019	0.000
	MG <sub>D_Mdn.abs</sub>	0.0260 $\pm$ 0.022	0.0073 $\pm$ 0.003	0.014
	TA <sub>D_Mean.abs</sub>	0.1402 $\pm$ 0.062	0.0218 $\pm$ 0.027	0.000
	MG <sub>D_Mean.abs</sub>	0.0333 $\pm$ 0.029	0.0111 $\pm$ 0.005	0.023
	TA <sub>Max.pow</sub>	18.0559 $\pm$ 7.059	5.2675 $\pm$ 4.508	0.000
	MG <sub>Max.pow</sub>	7.3701 $\pm$ 3.968	5.9154 $\pm$ 6.239	0.425

TA: Tibialis anterior, MG: medial gastrocnemius, Avg: average, SD: standard deviation.

**Table 5.** The comparison of variables obtained from the affected side of patients and the healthy subjects in PF position.

Position	Muscle	Normal side (healthy)	Hemiplegic side (patient)	P
		Avg $\pm$ SD	Avg $\pm$ SD	
Plantar flexion	TA <sub>Mean</sub>	0.0430 $\pm$ 0.025	0.0328 $\pm$ 0.022	0.270
	MG <sub>Mean</sub>	0.0662 $\pm$ 0.023	0.3796 $\pm$ 0.373	0.624
	TA <sub>Mean.abs</sub>	0.0194 $\pm$ 0.009	0.0158 $\pm$ 0.011	0.425
	MG <sub>Mean.abs</sub>	0.0366 $\pm$ 0.013	0.0208 $\pm$ 0.014	0.012
	TA <sub>Mean.SD</sub>	0.0255 $\pm$ 0.012	0.0205 $\pm$ 0.014	0.297
	MG <sub>Mean.SD</sub>	0.0487 $\pm$ 0.017	0.0282 $\pm$ 0.018	0.017
	TA <sub>D_Mdn.abs</sub>	0.0287 $\pm$ 0.021	0.0211 $\pm$ 0.019	0.462
	MG <sub>D_Mdn.abs</sub>	0.0634 $\pm$ 0.035	0.0166 $\pm$ 0.010	0.001
	TA <sub>D_Mean.abs</sub>	0.0388 $\pm$ 0.028	0.0281 $\pm$ 0.024	0.391
	MG <sub>D_Mean.abs</sub>	0.0848 $\pm$ 0.044	0.0246 $\pm$ 0.012	0.001
	TA <sub>Max.pow</sub>	6.7973 $\pm$ 2.915	7.0834 $\pm$ 4.135	0.902
	MG <sub>Max.pow</sub>	13.7121 $\pm$ 5.078	10.4933 $\pm$ 6.629	0.270

TA: Tibialis anterior, MG: medial gastrocnemius, Avg: average, SD: standard deviation.



$$\mu_{\bar{A}}(x; a_1, a_2, a_3, a_4) = \begin{cases} a_1 \leq x \leq a_2 & \text{if } (x - a_1) / (a_2 - a_1) \\ a_2 \leq x \leq a_3 & \text{if } 1 \\ a_3 \leq x \leq a_4 & \text{if } (a_4 - x) / (a_4 - a_3) \\ x > a_4 & \text{if } 0 \end{cases} \quad (2.2)$$

Fuzzy inference systems (FISs) are used for the output of fuzzy rules and also for adding (grouping) and clarification methods. The Mamdani-type FIS uses two different methods with the minimum–maximum (min-max) method and the maximum product (max-product) method. In our study, the min-max method in the Mamdani-type FIS was used. The preferred method for clarification is the center of gravity method and it is defined mathematically in Eq. (2.3).

$$Z^* = \frac{\int \mu_{\bar{C}}(z)zdz}{\int \mu_{\bar{C}}(z)dz} \quad (2.3)$$

Here,  $\int$  is the algebraic integration of the signal, whereas, by adding  $\mu_{\bar{C}}(z)$ , the output, which is obtained, expresses the membership function.

In this study, a FIS with multiple inputs and a single output was designed. Significant findings were obtained for the existence of spasticity by receiving expert opinions and different classifications were determined to be ISMG<sub>D-Mean.abs</sub>, PFMG<sub>D-Mean.abs</sub>, and DFTA<sub>D-Mean.abs</sub>-DFMG<sub>D-Mean.abs</sub> in the designed FIS system. Three variables were determined to be “ill”, “healthy”, and “indefinite” as the output variables. While the intervals of the trapezoidal memberships for each input group were determined, the database was determined based on the surface EMG measurement results and by taking the expert opinion as the basis. The fuzzification process was realized by discarding the linguistic variables in the value intervals measured for the input and output memberships. This is shown in Figure 4. Sixty-four rules were constituted by selecting every input and output variable (AND) connected element based on expert opinion. The different rules were weighted with respect to their contribution to the outcome variable. The combination of all sixty-four rules was performed by an aggregation process. Some proposals that were in fact impossible or very illogical according to expert opinion was not written as rules. Four of the rules constituted are shown in Table 6.

Subsequently, in the comparison conducted in MATLAB/Simulink, the FIS with rule imaging was applied. After setting up the FIS, the FLC system was tested with various input values. These test values were the values obtained from the real data set. The developed FLC system is shown in Figure 5. The rule imager displays how each one of the active rules for the membership functions and results affected by active rules are shown in Figure 6.

## 2.6. Performance tests of the classifiers

In this study, sensitivity, specificity, and accuracy criteria were used using the confusion matrix and the receiver operating characteristic (ROC) curve for evaluating the diagnostic adequacy of the FLC classifier of spasticity. The size of the area remaining under the ROC curve indicates the statistical significance of discrimination capability of the diagnostic test on which it operates. A classification was used in the interpretation of the areas below the ROC curve (0.90–1.00 = “perfect”, 0.80–0.90 = “good”, 0.70–0.80 = “average”, 0.60–0.70 = “weak”, and 0.50–0.60 = “unsuccessful”).

## 3. Results

### 3.1. Research on the pathological existence of spasticity

In standing positions (Table 2), all of the variables for either TA or MG muscles were not at a statistically significant level ( $P > 0.05$ ). In the resting position (Table 3), the difference of the MG<sub>D-Mdn.abs</sub> variable for the MG muscle between the patients ( $0.0039 \pm 0.00$ ) and healthy subjects ( $0.0025 \pm 0.00$ ) was at a statistically significant level ( $P < 0.05$ ). In the same manner, the difference of the MG<sub>D-Mean.abs</sub> variable for the MG muscle between the patients ( $0.0060 \pm 0.00$ ) and healthy subjects ( $0.0033 \pm 0.00$ ) was at a statistically significant level ( $P < 0.05$ ). These findings positively supported our hypothesis for the existence of spasticity in patients. In the DF position (Table 4), all variables for the TA muscle (TA<sub>Mean</sub>, TA<sub>Mean.abs</sub>, TA<sub>Mean.SD</sub>, TA<sub>D-Mdn.abs</sub>, TA<sub>D-Mean.abs</sub>, and TA<sub>Max.pow</sub>) were at a statistically significant level between the patients and healthy subjects ( $P < 0.05$ ). According to the results, there was not much of a difference between the TA and MG muscles in patients. This finding also supported our hypothesis. Thus, this differentiation was used for the fuzzy logic rule base. Another result was that there was a significant difference ( $P < 0.05$ ) between the MG<sub>D-Mdn.abs</sub> variable for the MG muscle for patients ( $0.0073 \pm 0.003$ ) and healthy subjects ( $0.0260 \pm 0.022$ ). In the same manner, the difference in the MG<sub>D-Mean.abs</sub> factor was significant ( $P < 0.05$ ) between the patients ( $0.0111 \pm 0.005$ ) and healthy subjects ( $0.0333 \pm 0.029$ ). The findings obtained for the MG<sub>D-Mean.abs</sub> and MG<sub>D-Mdn.abs</sub> variables positively supported both hypotheses, and these features were used for the fuzzy logic rule base. In the PF position (Table 5), all of the variables for the MG muscle apart from MG<sub>Max.pow</sub> were at a statistically significant level ( $P < 0.05$ ) between the patients and healthy subjects. In the amplitude variables for patients, such an increase was not observed between the MG and TA muscles. On the other hand, the increase in the amplitude variables for the MG muscle in patients was next to nothing or did not exist at all. This indicates other findings that have pathological significance, which supports the existence of spasticity and can be used in the classifier design.

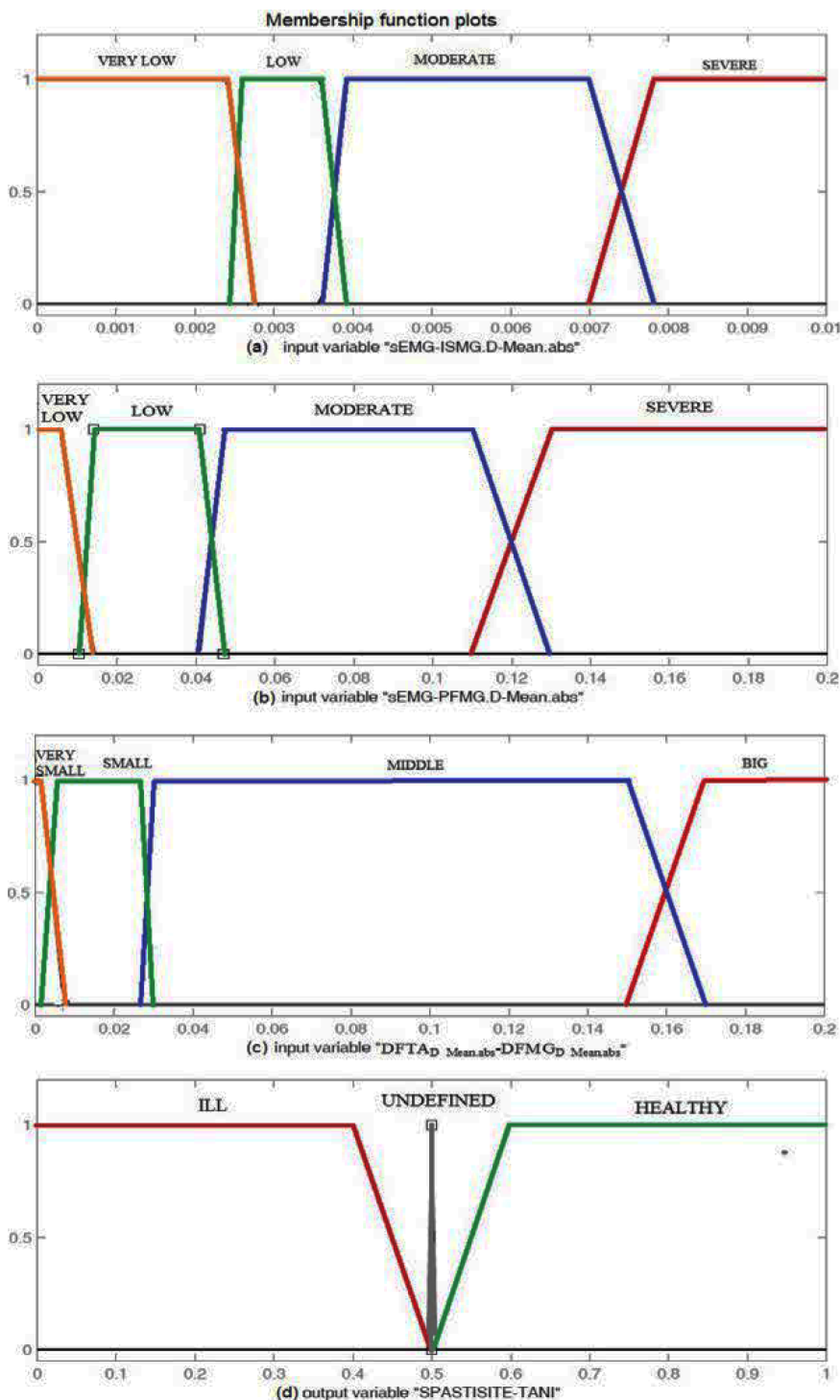

**Figure 4.** The fuzzification of the input and output membership function: a) input variable “ISMG<sub>D-Mean.abs</sub>”; b) input variable “PFMG<sub>D-Mean.abs</sub>”; c) input variable “DFTA<sub>D-Mean.abs</sub>-DFMG<sub>D-Mean.abs</sub>”; d) output variable “Spasticity Diagnosis”.

### 3.2. Performance tests of the classifiers designed

The accuracy of the FLC was tested with twenty-four actual data from the healthy and hemiplegic patient

groups. The performance of the FLC using the confusion matrix showed high rates of 95.8%, 100%, and 93.8%, respectively, for accuracy, sensitivity, and specificity. The

**Table 6.** Six rules of the FLC system.

Input memberships and connections							Output memberships
	ISMG <sub>D-Mean.abs</sub>		PFMG <sub>D-Mean.abs</sub>		DFTA <sub>D-Mean.abs</sub> / DFMG <sub>D-Mean.abs</sub> diff.		Diagnosis of spasticity
IF	“Very Low” 0.00282 mV	AND	“Very Low” 0.0149 mV	AND	“Very Small” 0.00885 mV	THEN	“Ill” 0.226
IF	“Low” 0.00386 mV	AND	“Moderate” 0.0832 mV	AND	“Small” 0.0235 mV	THEN	“Healthy” 0.776
IF	“Very Low” 0.00156 mV	AND	“Severe” 0.1674 mV	AND	“Big” 0.1855 mV	THEN	“Healthy” 0.776
IF	“Severe” 0.00913 mV	AND	“Very Low” 0.0115 mV	AND	“Small” 0.0165 mV	THEN	“Ill” 0.226

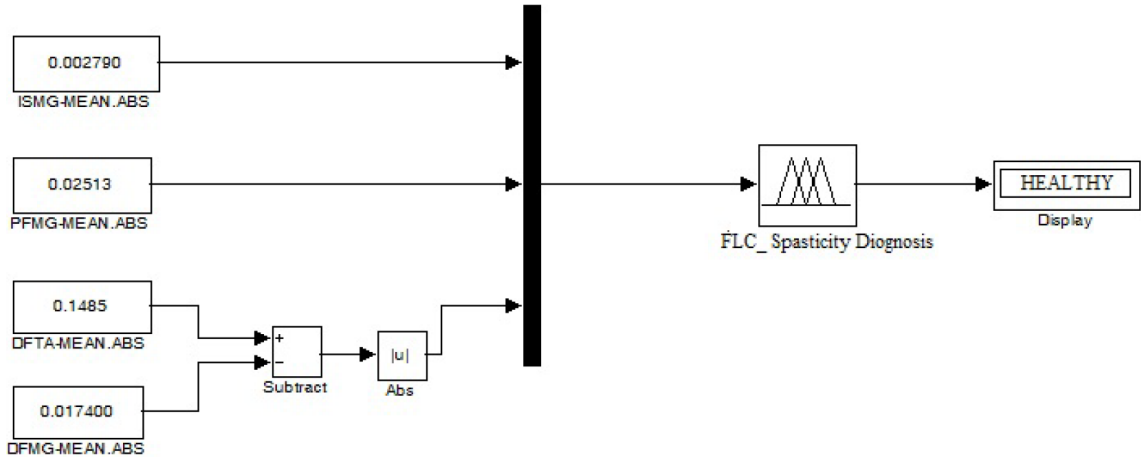

**Figure 5.** The FLC system.

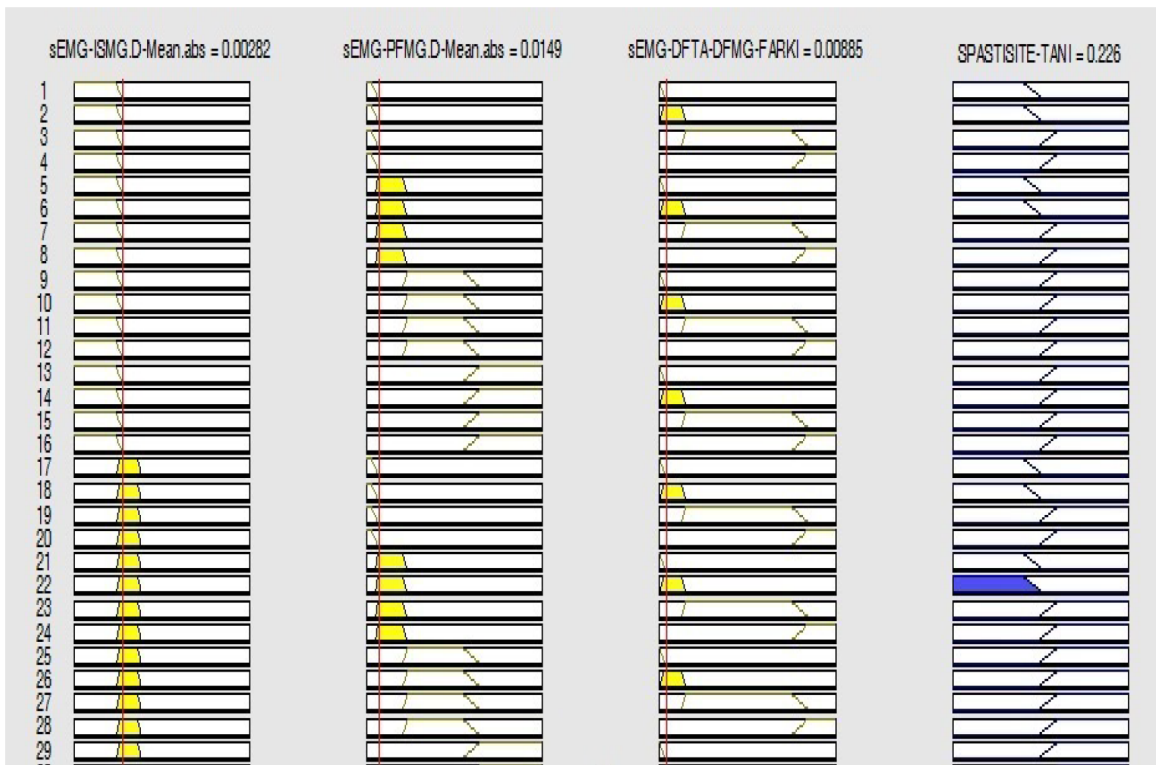

**Figure 6.** The rule viewer displays test data.

area remaining under the ROC curve for the classifier designed was calculated to be 0.969. This value showed that the results were at a “perfect” level. The ROC curve for the designed FLC for the diagnosis of spasticity is shown in Figure 7.

#### 4. Discussion

The surface EMG values for the MG muscles of hemiplegic patients with spasticity were higher compared to the healthy control group, particularly in the resting position. This situation, which appears even in extension at very low speeds, can be interpreted in the form of a muscular activity dependent on speed related to passive movement and can be the result of an increase in the resting muscle activity connected to an extension of resulting spasticity (26,27). We can state that the primary cause of spastic muscle hyper tonus is due to this increase in the extension reflex activity. However, increasing hardness in a spastic leg cannot only be interpreted directly as a proof of a hyperactive reflex, because increasing resistance in response to an extension can be attributed to passive tissue hardness (from connective tissue, tendons, ligaments, and passive muscle features). During the passive movements of

muscle activities, it has been reported that besides muscle activities producing increased resistance against passive extension, other mechanisms were responsible (13,28). Thus, the excessive extension or flexor reflexes that emerge in the muscles, especially with UMN syndrome, can contribute to spastic muscle tonus and to secondary changes in the internal and external muscle features, such as different muscle lengths, as well as the increasing resistance of a spastic muscle against extension (29).

The surface EMG values measured in the DF and PF positions were higher than those for resting and standing positions of the patients. This result is supported by studies in which it was reported that the surface EMG values obtained during rapid/active extension were more severe compared to slow extension (3). At the same time, it was also investigated what would be the most appropriate position for the measurement of spasticity. It was observed in other studies, which examined the ankle and upper extremity muscles, that the reflex responses were dependent in a similar manner on the muscle length and joint positions (7,30). This is probably due to the changes in the features of internal muscles and the length of the muscle. It was also set forth in different studies that increasing muscle length,

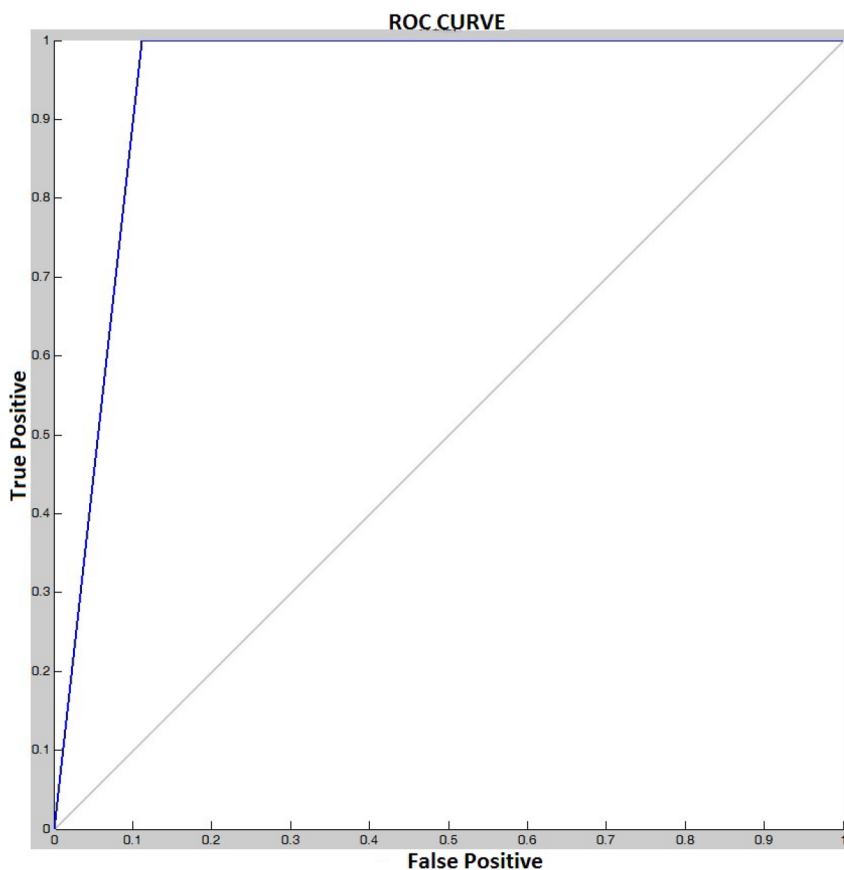

Figure 7. The ROC curve for designed FLC.

which is connected to the position of the large muscle groups, increased the extension reflex activity (31,32).

In our study, it was observed that the advantages provided by WT with the operation of the surface EMG signals provided superiority compared to STFT for obtaining supportive, useful data on spasticity and in producing features for the classifiers. Our results are in good agreement with the results obtained in many previous studies (33,34). Furthermore, our FLC system also supported previous studies that had similar results obtained with FL based on medical applications (35–37).

Our results provided positive conclusions on the subject of evaluating spasticity more objectively by using surface EMG. However, the limitations of surface EMG should also be taken into account. There are still no strict values to quantify the level of spasticity or to differentiate spastic muscles from normal muscles. However, using H-reflex or tendon vibration will provide additional electrophysiological information about the level of spasticity and a possible correlation between our results would support implementation of the surface EMG techniques in evaluation of spasticity (38). The examination of spasticity is realized mainly during passive joint movement. It is preferred to conduct the examination

in a slow manner. It is for this reason that not preferring passive but rather active joint movement openness could be questioned in the study. However, if evaluation had been done during passive joint movement openness, then the level obtained during active joint movement in normal individuals might not have been obtained in the surface EMG signals. Consequently, it is thought that the best evaluation could be obtained in subsequent studies where both the active and passive values are evaluated.

In conclusion, different signal analysis methods were compared and the WT technique in the analysis of the surface EMG signals presented advantages in this study. The FLC has high sensitivity, specificity, and accuracy in order to overcome the measurement difficulties existing in the causality of spasticity and the insufficiencies in clinical measurements. It can be considered a useful objective measurement method for the diagnosis of spasticity.

### Acknowledgments

This research was funded by the Scientific Research Fund of Gazi University (Project No: 07/2012-46). The authors would like to acknowledge the support of the Gazi University Medical Faculty, Associate Professor Fecir Duran, and Uğur Büyükelbaşı.

### References

- Pandyan AD, Gregoric M, Barnes MP, Wood D, van Wijck F, Burridge J, Hermens H, Johnson GR. Spasticity: clinical perceptions, neurological realities and meaningful measurement. *Disabil Rehabil* 2005; 27: 2-6.
- Nance PW, Satkunam L, Ethans K. Spasticity management. In: Braddom RL, editor. *Physical Medicine and Rehabilitation*. 4th ed. Philadelphia, PA, USA: Elsevier Saunders; 2011. pp. 638-656.
- Pandyan AD, van Wijck FMJ, Stark S, Vuadens P, Johnson GR, Barnes MP. The construct validity of a spasticity measurement device for clinical practice: An alternative to the Ashworth scales. *Disabil Rehabil* 2006; 28: 579-585.
- van der Krogt HJM, Meskers CGM, de Groot JH, Klomp A, Arendzen JH. The gap between clinical gaze and systematic assessment of movement disorders after stroke. *J Neuroeng Rehabil* 2012; 9: 61.
- Malhotra S, Pandyan AD, Day CR, Jones PW, Hermens HJ. Spasticity, an impairment that is poorly defined and poorly measured. *Clin Rehabil* 2009; 23: 651-658.
- Pandyan AD, Johnson GR, Price CI, Curless RH, Barnes MP, Rodgers H. A review of the properties and limitations of the Ashworth and modified Ashworth scales as measures of spasticity. *Clin Rehabil* 1999; 13: 373-383.
- Alibiglou L, Rymer WZ, Harvey RL, Mirbagheri MM. The relation between Ashworth scores and neuromechanical measurements of spasticity following stroke. *J Neuroeng Rehabil* 2008; 5: 18.
- Lebiedowska MK, Fisk JR. Knee resistance during passive stretch in patients with hypertonia. *J Neurosci Methods* 2009; 179: 323-330.
- Calota A, Feldman A, Levin MF. Spasticity measurement based on tonic stretch reflex threshold in stroke using a portable device. *Clin Neurophysiol* 2008; 119: 2329-2337.
- Starsky AJ, Sangani SG, McGuire JR, Logan B, Schmit BD. Reliability of biomechanical spasticity measurements at the elbow of people poststroke. *Arch Phys Med Rehab* 2005; 86: 1648-1654.
- Katz RT, Rovai CP, Brait C, Rymer WZ. Objective quantification of spastic hypertonia: correlation with clinical findings. *Arch Phys Med Rehab* 1992; 73: 339-347.
- Crone C, Johnsen LL, Biering-Sorensen F, Nielsen JB. Appearance of reciprocal facilitation of ankle extensors from ankle flexors in patients with stroke or spinal cord injury. *Brain* 2003; 126: 495-507.
- Nuyens GE, De Weerd WJ, Spaepen AJ, Kiekens C, Feys HM. Reduction of spastic hypertonia during repeated passive knee movements in stroke patients. *Arch Phys Med Rehab* 2002; 83: 930-935.
- Tekgöl H, Polat M, Tosun A, Serdaroglu G, Gökben S. Electrophysiologic assessment of spasticity in children using H-reflex. *Turkish J Pediatr* 2013; 55: 519-523.
- Burridge JH, Wood DE, Hermens HJ, Voerman GE, Johnson GR, van Wijck F, Platz T, Gregoric M, Hitchcock R, Pandyan AD. Theoretical and methodological considerations in the measurement of spasticity. *Disabil Rehabil* 2005; 27: 69-80.



16. Levin MF. On the nature and measurement of spasticity. *Clin Neurophysiol* 2005; 116: 1754-1755.
17. Miner NE. *An Introduction to Wavelet Theory and Analysis*. Albuquerque, NM, USA: Sandia National Laboratories; 1988.
18. Kumar DK, Pah ND, Bradley A. Wavelet analysis of surface electromyography to determine muscle fatigue. *IEEE T Neur Sys Reh* 2003; 11: 400-406.
19. Jobe TH, Helgason CM, Roitberg BZ. "Show me the numbers": the application of numbers to medical science. *Surg Neurol* 2001; 56: 3-7.
20. Helgason CM, Malik DS, Cheng SC, Jobe TH, Mordeson JN. Statistical versus fuzzy measures of variable interaction in patients with stroke. *Neuroepidemiology* 2001; 20: 77-84.
21. Canal MR, Zinnuroğlu M, Alcan V. Development of a user-friendly patient monitoring tool for the quantitative analysis of spasticity using surface EMG. *Turk J Phys Med Rehab* 2013; 59: 315.
22. Hermens HJ, Freriks B, Disselhorst-Klug C, Rau G. Development of recommendations for SEMG sensors and sensor placement procedures. *J Electromyogr Kines* 2000; 10: 361-374.
23. Phinyomark A, Phukpattaranont P, Limsakul C. Wavelet-based denoising algorithm for robust EMG pattern recognition. *Fluct Noise Lett* 2011; 10: 157-167.
24. Misiti M, Misiti Y, Oppenheim G, Poggi JM. *Wavelet Toolbox: The User's Guide*. Natick, MA, USA: The MathWorks Inc.; 2013.
25. LaBrunda M, LaBrunda A. Fuzzy logic in medicine. *J Inf Technol Res* 2008; 1: 27-33.
26. Lance JW. Pathophysiology of spasticity and clinical experience with baclofen. In: Feldman RG, Young RR, Koella WP. editors. *Spasticity*. Chicago, IL, USA: Year Book Medical Publishers; 1980. pp. 185-204.
27. Sheean G. Neurophysiology of spasticity. In: Barnes MP, Johnson GR. editors. *Upper Motor Neurone Syndrome and Spasticity: Clinical Management and Neurophysiology*. Cambridge, UK: Cambridge University Press; 2001. pp. 12-78.
28. McHugh MP, Kremenic IJ, Fox MB, Gleim GW. The role of mechanical and neural restraints to joint range of motion during passive stretch. *Med Sci Sport Exerc* 1998; 30: 928-932.
29. Finley JM, Perreault EJ, Dhafer YY. Stretch reflex coupling between the hip and knee: implications for impaired gait following stroke. *Exp Brain Res* 2008; 188: 529-540.
30. Kamper DG, Schmit BD, Rymer WZ. Effect of muscle biomechanics on the quantification of spasticity. *Ann Biomed Eng* 2011; 29: 1122-1134.
31. Fleuren JFM, Nederhand MJ, Hermens HJ. Influence of posture and muscle length on stretch reflex activity in poststroke patients with spasticity. *Arch Phys Med Rehab* 2006; 87: 981-88.
32. Vodovnik L, Bowman BR, Bajd T. Dynamics of spastic knee joint. *Med Biol Eng Comput* 1984; 22: 63-69.
33. Canal MR. Comparison of wavelet and short time Fourier transform methods in the analysis of EMG signals. *J Med Sys* 2010; 34: 91-94.
34. Kilby J, Mawston G, Hosseini HG. Continuous wavelet analysis and classification of surface electromyography signals. In: *World Congress on Medical Physics and Biomedical Engineering*; 2006. pp. 1034-1036.
35. Koçer S. Classification of EMG signals using neuro-fuzzy system and diagnosis of neuromuscular diseases. *J Med Sys* 2010; 34: 321-329.
36. Kılıç YA, Konan A, Yorgancı K, Sayek İ. A novel fuzzy-logic inference system for predicting trauma-related mortality: emphasis on the impact of response to resuscitation. *Eur J Trauma Emerg S* 2010; 36: 543-550.
37. Datta S, Sajja BR, He R, Wolinsky JS, Gupta RK, Narayana PA. Segmentation and quantification of black holes in multiple sclerosis. *Neuroimage* 2006; 29: 467-474.
38. Hilgevoord AA, Koelman JH, Bour LJ, de Visser BW. The relationship between the soleus H-reflex amplitude and vibratory inhibition in controls and spastic subjects. *J Electromyogr Kinesiol* 1996; 6: 253-258.