

1-1-2017

## Minimizing reverse current flow due to distributed generation via optimal network reconfiguration

JASRUL JAMANI JAMIAN

MUHAMMAD MOHSIN AMAN

MUHAMMAD ARIFF BAHARUDDIN

AHMAD SAFAWI MOKHTAR

MOHD NOOR ABDULLAH

Follow this and additional works at: <https://journals.tubitak.gov.tr/elektrik>



Part of the [Computer Engineering Commons](#), [Computer Sciences Commons](#), and the [Electrical and Computer Engineering Commons](#)

---

### Recommended Citation

JAMIAN, JASRUL JAMANI; AMAN, MUHAMMAD MOHSIN; BAHARUDDIN, MUHAMMAD ARIFF; MOKHTAR, AHMAD SAFAWI; and ABDULLAH, MOHD NOOR (2017) "Minimizing reverse current flow due to distributed generation via optimal network reconfiguration," *Turkish Journal of Electrical Engineering and Computer Sciences*: Vol. 25: No. 4, Article 47. <https://doi.org/10.3906/elk-1603-174>  
Available at: <https://journals.tubitak.gov.tr/elektrik/vol25/iss4/47>

This Article is brought to you for free and open access by TÜBİTAK Academic Journals. It has been accepted for inclusion in Turkish Journal of Electrical Engineering and Computer Sciences by an authorized editor of TÜBİTAK Academic Journals. For more information, please contact [academic.publications@tubitak.gov.tr](mailto:academic.publications@tubitak.gov.tr).

## Minimizing reverse current flow due to distributed generation via optimal network reconfiguration

Jasrul Jamani JAMIAN<sup>1,\*</sup>, Muhammad Mohsin AMAN<sup>2</sup>, Muhammad Ariff BAHARUDIN<sup>1</sup>,  
Ahmad Safawi MOKHTAR<sup>1</sup>, Mohd Noor ABDULLAH<sup>3</sup>

<sup>1</sup>Faculty of Electrical Engineering, Universiti Teknologi Malaysia, Johor Bahru, Malaysia

<sup>2</sup>Department of Electrical Engineering, NED University, Karachi, Pakistan

<sup>3</sup>Faculty of Electrical and Electronics Engineering, Universiti Tun Hussein Onn Malaysia, Batu Pahat, Johor, Malaysia

Received: 16.03.2016

Accepted/Published Online: 23.12.2016

Final Version: 30.07.2017

**Abstract:** Distributed generation (DG) is widely used to minimize total power losses in distribution networks. However, one of the problems of DG in a grid system is reverse current flow (RCF), which is when the DG output becomes greater than the connected load. Therefore, this paper proposes a multiobjective artificial bee colony (MOABC) algorithm to determine the optimal network reconfiguration for reducing total RCF in DG. The proposed algorithm is tested on 33-bus radial distribution systems in two different scenarios, i.e. base case and with 50% load. The proposed technique can reduce reverse current by up to 93%; however, the total power loss in the system will increase by 7%. Therefore, a suitable weight value is needed in MOABC for balancing the effect of RCF and the power loss value.

**Key words:** Distributed generation, reverse current flow, artificial bee colony, multiobjective optimization

### 1. Introduction

With the advent of restructuring in power systems, different steps are being taken to improve their overall efficiency and reliability, including placement of distributed generation (DG) units nearer to the load demand. DG normally includes solar, wind, biomass, combined heat and power, or small rating power plant. The main advantages of DG include low investment cost, managing transmission line congestion [1,2], reduction in greenhouse gas emission [3], minimization of power losses [4,5], possible islanding operation that minimizes interruption time, and increased reliability [6–8]. Thus, many researchers are focusing on optimizing DG size or placement in distribution networks, with different objective functions to improve its performance.

DG placement changes the nature of the power system from a passive to an active network. Different issues are being observed due to this changing nature of the system, including changing fault level, reduced reach of impedance, and islanding operations [9–12]. Reverse current flow (RCF) in different branches of the network is also a major issue due to DG placement. RCF affects the loading of the network. For example, when DG penetrations exceed the minimum in the front feeder load, the net power flow of the feeder will be reversed (i.e. towards the main substation), particularly during the light load [13]. Such RCF may affect the settings of existing fuses and other protection devices. Although changing the existing protection devices to ones with high protection ratings may solve the RCF problem, this solution is not feasible due to the high initial

\*Correspondence: [jasrul@fke.utm.my](mailto:jasrul@fke.utm.my)

cost. Therefore, in this paper, a new strategy based on network reconfiguration has been proposed to reduce the amount of RCF due to DG placement. In the literature [14–16], network reconfiguration has been used to minimize total active power losses in networks. However, by varying the position of the tie and sectionalizing switches, the topological structures of the distribution system and the power flow in the network changes. This idea can be applied to solving the RCF problem in such a way that total RCF is reduced.

In this paper, the optimization technique (a multiobjective artificial bee colony, (MOABC)) will try to obtain the optimal configuration for the distribution network, with the objective of minimizing RCF as well as power loss. This paper is organized as follows: in Section 2, the problem of reducing total RCF and total power loss is formulated. The implementation of the MOABC process is discussed in Section 3. A simple additive weighting approach has been utilized to combine both objective functions. In Section 4, the results are presented and discussed in detail.

## 2. Problem formulation

RCF in a distribution network cannot be avoided when the DG output is larger than the upfront feeder load, as shown in Figure 1. Reverse current helps reduce power losses in the distribution system, but it also affects the protection settings of the distribution system, including the fuse and circuit breaker. Thus, in this study, the network reconfiguration technique is used as an alternative method to reduce RCF in the distribution system.

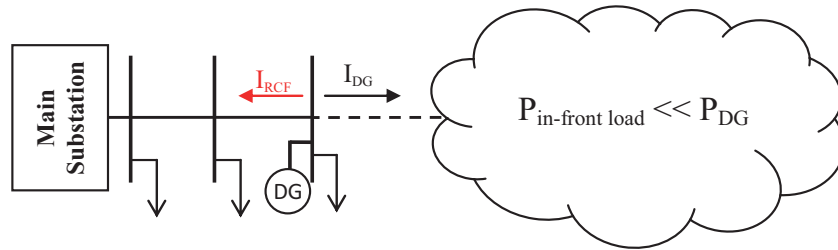

**Figure 1.** The reverse current flow phenomenon in a radial distribution network.

By using the optimization technique, the algorithm tries to determine the best new configuration of the system with minimum RCF and power loss. The total power loss in the system can be determined by using a standard power loss formula as shown in Eq. (1).

$$P_{losses} = \sum_{i=1}^L |I_i|^2 R_i, \tag{1}$$

where

- $I_i$  = current flow in the  $i$ th line.
- $R_i$  = resistance of the  $i$ th line.
- $L$  = total number of lines.

For the total RCF, the direction of the reverse current is monitored during load flow analysis. By assuming that the direction of initial current in the system (without DG) is positive, the changes in current direction (from the receiving bus to the sending bus) are recorded and the summation for the reverse current due to DG optimal output is done using Eq. (2).

$$RCF_{total} = - \sum_{i=1}^h I_i = - \sum_{i=1}^h \left( \frac{V_j \angle \delta_j - V_k \angle \delta_k}{r_{jk} + jx_{jk}} \right), \tag{2}$$

where

$h$  = number of DG units causing RCF

$j$  = sending bus

$k$  = receiving end bus

$r_{jk}$  = resistive value from  $j$  to  $k$  buses

$x_{jk}$  = reactance value from  $j$  to  $k$  buses

$\delta$  = receiving bus voltage angle

The negative sign in the  $RCF_{total}$  equation is due to the reverse current that occurs in the network. Other constraints that need to be considered in network reconfiguration analysis are as follows:

a) Radial configuration:

The radial nature of the network should be maintained for every switch combination during the optimization process.

b) Isolation constraint:

All buses in the system need to be energized in order to make all loads in the network receive the generated power. In other words, there are no load disconnections during the reconfiguration process.

Therefore, all the constraints and objective functions that are described in this section are used during the optimization process. The MOABC algorithm determines the optimum configuration of the network with minimum power losses and reduced reverse current.

### 3. Implementation of the MOABC

The artificial bee colony (ABC) was introduced by [17] to solve the optimization problem, based on analyzing the behavior of bees searching for food. In ABC, 3 groups of bees (employer bees, onlooker bees, and scout bees) are constructed to find food positions. Each group of bees has their own responsibility in the process of finding the best solution. The initial scout bees are set out randomly in the search space for finding the initial nectar (solution), and the information obtained by the initial scout bee is passed down to the employer bees. Then the employer bees look for neighboring food (location) based on the initial bees' information, using Eq. (3). The information obtained by the employer bees is passed on to the onlooker bees. However, whether the onlooker bee goes to the next neighboring location depends on the amount of nectar available (the strength of solution – “probability”) given in Eq. (4). Therefore, it is possible that some food source locations might not be visited by any onlooker bee due to the small amount of nectar. When the food in the search area has been depleted, the onlooker bees will now become the scout bees again and look for the new food sources in random locations. The whole process will be repeated until the maximum iteration value set by the user is reached.

$$x_{ij}^{new} = x_{ij}^{old} + range (x_{ij}^{old} - x_{kj}) \quad (3)$$

$$P(f(x_i)) = \frac{Fitness(f(x_i))}{\sum_{i=1}^n Fitness(f(x_i))} \quad (4)$$

where

- $x$  = optimized parameter than needs to be found (bees)
- $x_{ij}$  = value of  $i$ th bees at random  $j$ th dimension
- $x_{kj}$  =  $k$ th bees that are selected randomly from  $j$ th dimension
- $f(x_i)$  = solution value for  $i$ th bee
- Fitness* = strength of the solution

In the present case of network reconfiguration analysis, the “bees” in the algorithm represent the opened switch condition in the distribution network. The two objective functions in the analysis are total power loss and total RCF. A simple additive weighting approach is adopted in the original ABC to create the MOABC. Furthermore, since the fitness unit between both objective functions is different (power loss in kW and RCF in A), the normalization process, using Eq. (5), is needed to add both objective functions’ results, as shown in Eq. (6). From Eqs. (5) and (6), the “bee” that has the minimum value in each objective function will give the lowest new objective function ( $f(x)_i^{new}$ ) compared to the other bees in the population and indirectly give the higher fitness value (*Fitness*  $f(x)$ ) as shown in Eq. (7).

$$Norm f(x_i) = \frac{f(x_i)}{f(x_i)_{min-iter}} \tag{5}$$

$$f(x_i)^{new} = \sum_{b=1}^{MaxObj} w_b(Norm f_b(x_i)) \tag{6}$$

$$Fitness f(x_i)^{new} = \frac{1}{1 + f(x_i)^{new}}, \tag{7}$$

where

- $f(x_i)$  = solution value for  $i$ th bee
- $f(x_i)_{min-iter}$  = minimum value achieved by  $N$  bees in current iteration
- $w$  = weight parameter for each objective function
- $b$  = number of objective functions (in this analysis, “*MaxObj*” = 2)

Figure 2 shows the pseudocode for implementing the MOABC in the reconfiguration process. In this analysis, the number of bees ( $N$ ) is set to 40, the maximum iteration (max iter) is 300, and the limit to activate the scout bee (limit) is set to 100.

#### 4. Results and discussion

MOABC’s performance in optimizing network reconfiguration is tested on a standard 33-bus radial distribution test system (Figure 3) under two different scenarios.

Scenario 1: 33-Bus distribution system with 100% loading

Scenario 2: 33-Bus distribution system without any DG

Three DG units based on minimization of losses are also located on bus 6, bus 16, and bus 25 to generate the reverse current in the distribution line. The discussions in the next subsection will focus on analyzing power loss and reverse current based on the following cases:

- Case 1: Distribution system without any DG
- Case 2: Distribution system with optimal DG output via ABC
- Case 3: Distribution system with optimal DG output & reconfiguration via MOABC

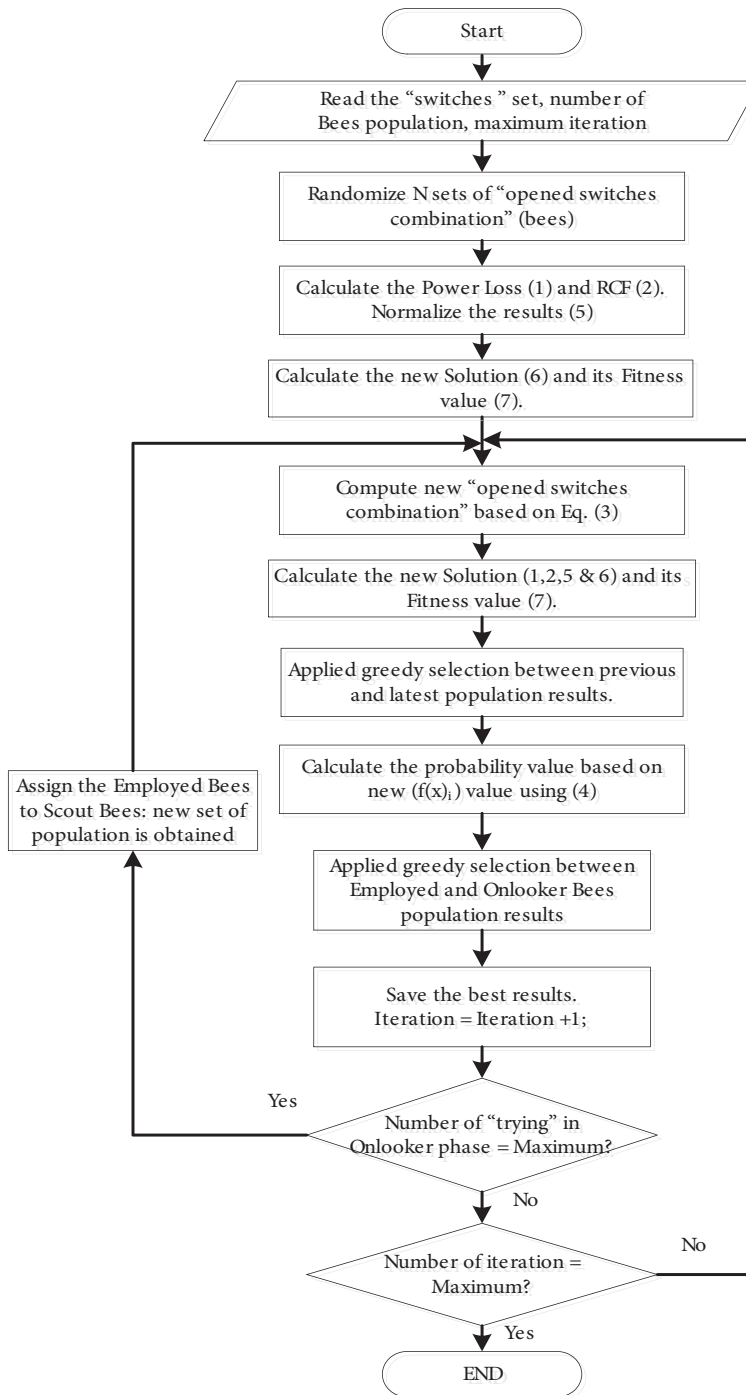

Figure 2. Pseudocode for MOABC.

#### 4.1. Scenario 1: Standard 33-bus radial distribution system

Table 1 shows the power loss and RCF value for cases 1 and 2. The power loss in the network is reduced from 203.1854 kW to 33.2618 kW, which is an 83.63% decrease from the original power loss value when the connected DG operates optimally. However, the reverse current caused by DG in the system becomes 75.93 A, which is

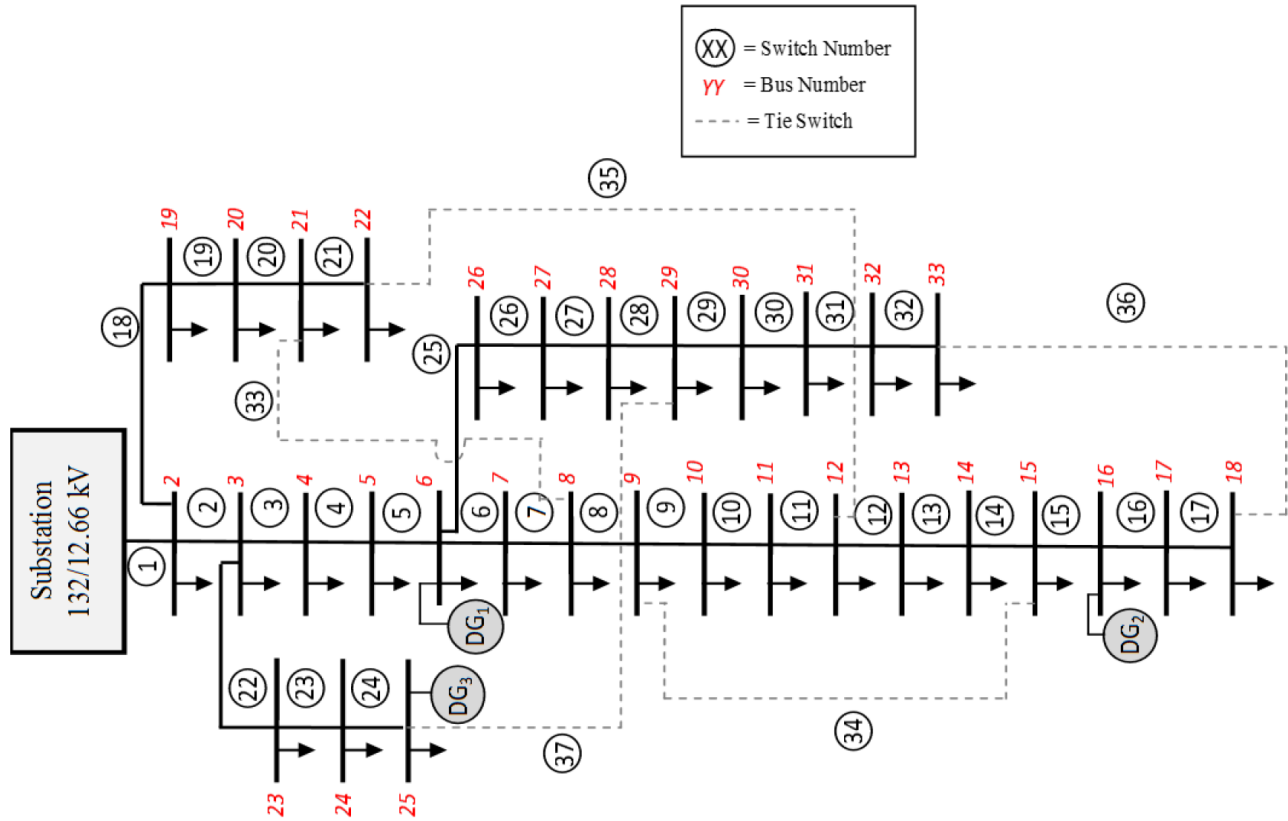

Figure 3. 33-Bus distribution system with 3 DG units.

very large. Thus, in order to reduce RCF, the reconfiguration process is applied to minimize the power loss and RCF using MOABC.

Table 1. The comparison of power loss and RCF with optimal DG output.

DG size <sub>(location)</sub>	Tie switches position	Power loss (kW)	Total reverse current (A)
Without DG	33, 34, 35, 36, 37	203.1854	0.00
With three DG units DG <sub>6</sub> = 1.7076 MW DG <sub>16</sub> = 0.5470 MW DG <sub>25</sub> = 0.7695 MW	33, 34, 35, 36, 37	33.2618	75.93

In the next step, case study 3 is carried out with 5 different weightage values ( $w_1$  and  $w_2$ ) for power loss and RCF, respectively, and the results are shown in Table 2.

From Table 2, the following points can be concluded:

1. The weightage of power loss minimization has been configured to maximum ( $w_1 = 1$ ) and RCF to zero ( $w_2 = 0$ ) in combination 1. As a result, the power losses have been reduced to the lowest value. Furthermore, RCF has also been reduced by 21.43% compared to the results in case 2 (distribution system with optimal DG output).

**Table 2.** Optimal configuration based on weight values.\*  
—vs3mm

Combinations	Weightage**		Opened switches	Power loss (kW)	Total reverse current (A)
	$w_1$	$w_2$			
1	1.0	0.0	20, 24, 32, 34, 35	20.5260	59.66
2	0.7	0.3	13, 15, 20, 24, 35	22.9677	27.76
3	0.5	0.5	11, 12, 15, 19, 24	24.5337	22.38
4	0.3	0.7	3, 13, 15, 24, 35	29.5457	16.69
5	0.0	1.0	4, 15, 24, 34, 35	37.4126	5.30

\*Three DGs are also presented in the system at bus numbers 6, 16, and 25 ( $DG_1 = 1.7076$ ,  $DG_2 = 0.5470$ ,  $DG_3 = 0.7695$ ).

\*\* $w_1$  and  $w_2$  are weighted functions to control the objective function. Here  $w_1$  represents the loss function weightage and  $w_2$  represents reverse current.

- By increasing the weightage of  $w_2$  (combinations 2–5), the value of RCF is further decreased (Figure 4). However, the power loss has opposite results, where it has slowly increased.

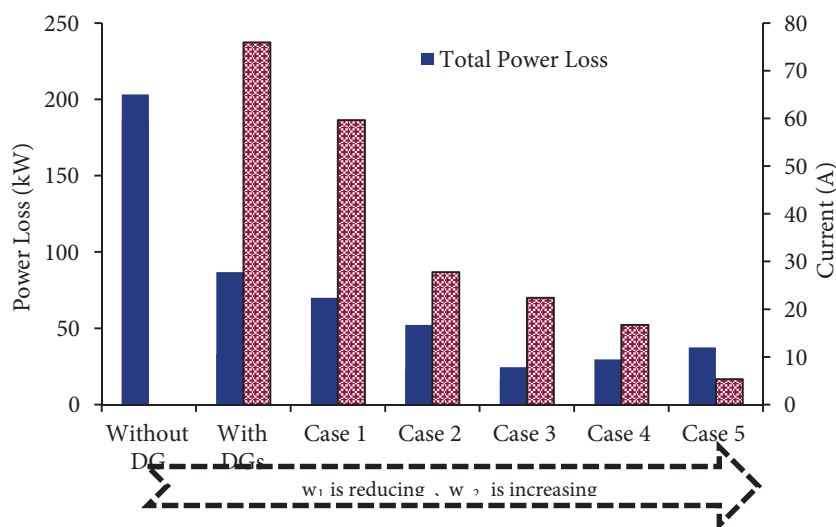

**Figure 4.** The power loss and reverse current results after obtaining optimal configuration.

- In order to get an inside view of the total RCF, the contribution of different DG units in total RCF for different combinations is determined. The results are tabulated in Table 3. The results show that before the network reconfiguration, all three DGs caused RCF, and the largest RCF occurred in the line between buses 24 and 25. However, after the network reconfiguration implementation (combination 1), only 2 DGs units contribute to RCF. However, when the weight of RCF in MOABC is increased, only a single DG unit at bus 6 causes RCF (combinations 2–5).

In conclusion, the network will have very high RCF in certain branches if the optimization is only focused on minimizing power loss, and vice versa. Thus, with the use of a suitable weight in MOABC, the algorithm will determine a new configuration that is able to give low RCF as well as a smaller power loss increment.

Scenario 2: Standard 33-bus distribution system with 50% load

In order to validate the performance of the proposed network reconfiguration algorithm, a higher reverse current is formed in the system by increasing the loading factor ( $\lambda$ ) to 50% on all buses in a standard 33-bus



**Table 3.** DG contribution in reverse current value and reconfiguration action.

Cases		Sending bus	Receiving bus	RCF (A)
With Optimal DG (w/o network reconfiguration)		5	6	15.18
		15	16	30.05
		24	25	30.71
		Total		75.93
With optimal DG placements and network reconfiguration	Combination 1	5	6	27.98
		15	16	31.68
		Total		59.66
	Combination 2	5	6	27.76
		Total		27.76
	Combination 3	5	6	22.38
		Total		22.38
	Combination 4	5	6	16.69
		Total		16.69
	Combination 5	5	6	5.30
		Total		5.30

network, as shown in Eqs. (8a) and (8b).

$$P_{L1} = (1 + \lambda) P_{L0} = \lambda P_{L0} \tag{8}$$

$$Q_{L1} = (1 + \lambda) Q_{L0} = \lambda Q_{L0},$$

where

$P_{L0}$  and  $Q_{L0}$  = the initial active and reactive load on all buses, respectively.

$P_{L1}$  and  $Q_{L1}$  = the modified active and reactive load on all buses, respectively.

$\lambda$  = loadability factor. In the present case,  $\lambda$  is equal to 50.

By using an ABC algorithm, optimal DG placement and outputs were found at bus 6, bus 15, and bus 25 with 2.5854 MW, 0.8215 MW, and 1.1545 MW, respectively, for DG<sub>1</sub>, DG<sub>2</sub>, and DG<sub>3</sub>. The results are tabulated in Table 4.

**Table 4.** The optimal opened switch results for modified 33-bus distribution network.

DG size <sub>(location)</sub>	Opened switch	Power loss (kW)	Total reverse current (A)
Without DG	33, 34, 35, 36, 37	498.5787	0.00
With three DG units DG <sub>6</sub> = 2.5854 DG <sub>16</sub> = 0.8215 DG <sub>25</sub> = 1.1545	33, 34, 35, 36, 37	76.7730	114.06

The data in Table 4 show that the total power loss in the system decreased from 498.5787 kW to 76.7730 kW. However, 114.06 A of RCF existed in the system due to these optimal DGs' output. Therefore, in order to reduce RCF, the MOABC algorithm is applied where the corresponding weightage of total power loss and total RCF varies ( $w_1$  and  $w_2$ ). Table 5 shows the performance of network reconfiguration action and the following points can be concluded:

1. By opening the optimum switch combinations 20, 24, 32, 34, and 35 and closing the other switches, RCF and power loss in the system were reduced by 21% and 39% respectively (combination 1).

**Table 5.** Optimal configuration based on weight values.\*

Cases	Weightage**		Opened switches	Power loss (kW)	Total RCF (A)
	$w_1$	$w_2$			
Combination 1	1.0	0.0	20, 24, 32, 34, 35	46.8904	90.80
Combination 2	0.7	0.3	13, 15, 20, 24, 35	52.3316	42.61
Combination 3	0.5	0.5	10, 12, 15, 20, 24	53.3925	42.52
Combination 4	0.3	0.7	3, 11, 13, 15, 24	70.8798	25.06
Combination 5	0.0	1.0	4, 12, 15, 24, 35	82.6204	7.95

\*Three DGs are also presented in the system at bus numbers 6, 16, and 25 ( $DG_1 = 1.7076$ ,  $DG_2 = 0.5470$ ,  $DG_3 = 0.7695$ )

\*\* $w_1$  and  $w_2$  are weighting coefficients to control the objective function.  $w_1$  represents the loss function weightage while  $w_2$  represents reverse current.

2. Similar to previous discussions, increasing  $w_2$  values in the MOABC reduces total RCF in the system and causes a small increase in total power losses.
3. Comparing the results for combinations 1 and 5, the small increase in power loss (7.61%) is acceptable compared to the 93% reduction in RCF (Figure 5). Furthermore, it is clear that the number of RCF-causing DGs is also reduced from 3 units to just 1 unit in combination 5.

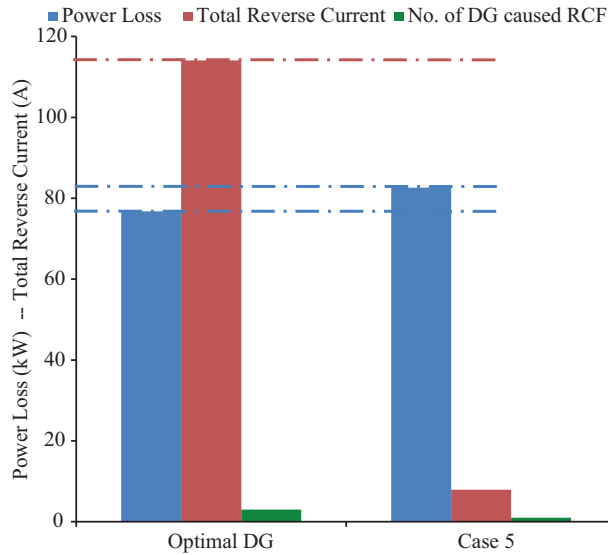

**Figure 5.** The comparison between optimal DG and reconfiguration (case 5) results.

From the discussion, it has been proven that when considering RCF in finding optimal reconfiguration, the impact of protection malfunction in the distribution network can be reduced. Furthermore, the increment of load in the system indirectly causes the reverse current to become worse. Thus, the reconfiguration process can be done regularly with the load increment without any additional cost required.

### 5. Conclusion

RCF caused by DG placement in the distribution network may affect the setting of existing fuse and other protection devices. Therefore, in this paper, a strategy based on network reconfiguration has been adopted to

solve the RCF problem in the presence of DGs. A MOABC algorithm is used to balance the impact of RCF as well as power loss. The proposed method is tested on standard and modified 33-bus radial distribution networks. From the results, the following points can be concluded.

1. Using a simple additive weightage approach, total RCF can be reduced by up to 80%–90%; however, the total active power loss will increase. According to the results, the total active power loss at optimum solution is still 80% less than without DG.
2. The network reconfiguration process not only reduces the total RCF in the network, but also reduces the number of DG units that contribute in the RCF phenomenon.

From these results, it can be concluded that implementing MOABC in the reconfiguration process, with power loss and RCF as the objective functions, tremendously improved power system performance, especially in terms of RCF and power loss reductions.

### References

- [1] Sasiraja RM, Kumar VS, Ponmani S. An elegant emergence of optimal siting and sizing of multiple distributed generators used for transmission congestion relief. *Turk J Elec Eng & Comp Sci* 2015; 23: 1882-1895.
- [2] Singh AK, Parida SK. Benefits associated with distributed generation to remove transmission overloads. In: Proceedings of the International Conference and Utility Exhibition on Green Energy for Sustainable Development; 19–21 March 2014; Pattaya, Thailand. New York, NY, USA: IEEE. pp. 1-3.
- [3] Busam S, Hota S, Kumar GVN, Naidu RSRK. Multiobjective optimization of radial distribution system with multiple distributed generation units using genetic algorithm. In: Proceedings of the International Conference on Electrical, Electronics, Signals, Communication and Optimization; 24–25 January 2015; Andhrapradesh, India. New York, NY, USA: IEEE. pp. 1-5.
- [4] Sultana U, Khairuddin AB, Aman MM, Mokhtar AS, Zareen N. A review of optimum DG placement based on minimization of power losses and voltage stability enhancement of distribution system. *Renew Sust Energ Rev* 2016; 63: 363-378.
- [5] Tahboub AM, Pandi VR, Zeineldin HH. Distribution system reconfiguration for annual energy loss reduction considering variable distributed generation profiles. *IEEE T Power Deliver* 2015; 30: 1677-1685.
- [6] Nayeripour M, Mahboubi-Moghaddam E, Khooban MH. Multi-periods distribution feeder reconfiguration at the presence of distributed generation through economic assessment using a new modified PSO algorithm. *J Intell Fuzzy Syst* 2016; 31: 321-331.
- [7] Tu L, Liu D, Liao Q, Zhu Z, Ji X. Reliability evaluation considering storage capacity optimization for distribution system with wind-PV-storage. *Electr Pow Automat Equip* 2015; 35: 40-46.
- [8] Battu NR, Abhyankar AR, Senroy N. DG planning with amalgamation of economic and reliability considerations. *Int J Elec Power* 2015; 73: 273-282.
- [9] Lin X, Shi Y, Li Q, Gao H. Research on the protection strategy of distribution automation system based on DG access. *Power System Protection and Control* 2016; 44: 137-144.
- [10] Basak P, Chowdhury S, Halder Nee Dey S, Chowdhury SP. A literature review on integration of distributed energy resources in the perspective of control, protection and stability of microgrid. *Renew Sust Energ Rev* 2012; 16: 5545-5556.
- [11] Sharma A, Srinivasan D, Trivedi A. A decentralized multiagent system approach for service restoration using DG islanding. *IEEE T Smart Grid* 2015; 6: 2784-2793.

- [12] Marchesan G, Muraro MR, Cardoso G, Mariotto L, Da Silva CDL. Method for distributed generation anti-islanding protection based on singular value decomposition and linear discrimination analysis. *Electr Pow Syst Res* 2016; 130: 124-131.
- [13] Kroposki B, Vaughn A. DG power quality, protection, and reliability case studies report. In: NREL/Sr-560-34635. Golden, CO, USA: National Renewable Energy Laboratory, 2003.
- [14] Nawaz S, Imran M, Sharma AK, Jain A. Optimal feeder reconfiguration and DG placement in distribution network. *Int J Applied Eng Re* 2016; 11: 4878-4885.
- [15] Syahputra R, Robandi I, Ashari M. PSO based multi-objective optimization for reconfiguration of radial distribution network. *International Journal of Applied Engineering Research* 2015; 10: 14573-14586.
- [16] Niknam T, Farsani EA, Nayeripour M, Bahmani Firouzi B. A new tribe modified shuffled frog leaping algorithm for multi-objective distribution feeder reconfiguration considering distributed generator units. *Eur T Electr Power* 2012; 22: 308-333.
- [17] Karaboga N. A new design method based on artificial bee colony algorithm for digital IIR filters. *J Franklin Institute* 2009; 346: 328-348.