

Effects of genetic relatedness, spatial distance, and context on intraspecific aggression in the red wood ant *Formica pratensis* (Hymenoptera: Formicidae)

Volkan AKSOY*, Yılmaz ÇAMLITEPE

Department of Biology, Faculty of Sciences, Trakya University, Edirne, Turkey

Received: 12.08.2017 • Accepted/Published Online: 06.02.2018 • Final Version: 04.05.2018

Abstract: In the present study, we tested the level of aggression of monodomous and polydomous colonies of the wood ant *Formica pratensis* (Hymenoptera: Formicidae) with a behavioral assay in nature and laboratory conditions to see if the ants from neighboring colonies are more tolerant or more aggressive to each other than those from greater distances. We also tested how context (nature and laboratory conditions) affected aggression. Our results showed that the monodomous colonies were highly aggressive to all neighboring or nonneighboring conspecifics in nature irrespective of the spatial distance. The polydomous colony showed no aggression towards neighboring conspecifics but the level of aggression increased with increasing spatial distance between the colonies. The level of aggression of tested colonies in laboratory conditions was significantly low, irrespective of whether they were monodomous or polydomous, indicating that aggression is context dependent. A DNA barcoding technique based on mitochondrial COI gene sequencing was applied to determine the genetic relatedness between the colonies. The results of the genetic analysis, in combination with results of behavioral assays, revealed that aggression behavior of the polydomous colony was affected by both the genetic relatedness and the spatial distance between the colonies while there was no clear separation of effects of genetic relatedness and spatial distance on aggression in the monodomous colonies.

Key words: Context-dependent aggression, intraspecific aggression, social structure, dear enemy effect, nasty neighbor effect, DNA barcoding

1. Introduction

The integrity of an ant colony is an important task for maintenance of sociality and discrimination of colony members (nestmates) from noncolony members (nonnestmates) is a key factor providing the integrity (Guerrieri et al., 2009). Nestmate discrimination in ants is dominantly mediated by the use of chemical cues, cuticular hydrocarbons (CHCs) located on the surface of the body (Torres et al., 2007; Martin et al., 2008; Bos and d'Ettoire, 2012). The recognition cues may have genetic (Vander Meer and Morel, 1998; Martin and Drijfhout, 2009) or environmental components (Heinze et al., 1996; Liang and Silverman, 2000) such as diet, nest material, and physical contacts among members of a colony. Colony members possess a common colony odor (recognition label) by means of trophallaxis and allogrooming (Lenoir et al., 2001; Chapuisat et al., 2005), helping them to decide to trigger aggressive and/or acceptance behavior towards an intruder depending on the level of the mismatch and/or overlap between the cues the intruder bears and the colony odor. Ants can show intra- or interspecific aggressive

behaviors towards threats but the level of aggression differs from one to another species (Foitzik et al., 2007). The level of aggression is reported to be low in multiple-queen colonies because such colonies are characterized by an increased diversity of recognition cues. Thus, in a multiple-queen colony, workers recognize a wide range of cues and become less hostile to intruders (Bennett, 1989; Morel et al., 1990; Sundström, 1997; Vander Meer and Morel, 1998; Tsutsui et al., 2003; Holzer et al., 2006). By contrast, single-queen colonies are genetically less diverse and are more hostile to intruders (Rosset et al., 2007). For instance, in an earlier study with *Formica exsecta*, Pisarski (1982) showed that aggression towards aliens was high in monodomous colonies compared to polydomous ones (see also Kiss and Kóbori, 2010).

One way to investigate nestmate recognition in ants is to perform behavioral aggression tests (Gamboia et al., 1991; Roulston et al., 2003). The level of aggressive behavior is expected to be low between ants from nearby colonies compared to aggression towards conspecifics from more distant colonies when environmental cues

* Correspondence: volkanaksoy@trakya.edu.tr

determine the recognition cues since these ants will share a large proportion of chemicals. When recognition cues are genetically determined, ants from related colonies will share more cues and thus are expected to be less aggressive to each other than towards unrelated conspecifics whatever the geographical distance between the colonies or their environmental conditions are.

In the present study, we examined the level of aggression in a natural population of the wood ant *Formica pratensis* Retzius, 1783 in Turkish Thrace. *F. pratensis* is a mound building ant species and can form polygyne colonies with several functional queens (Seifert, 1996), but monogyny is frequent (Rosengren et al., 1993). It is known that some of the characteristics of ant species are expressed in varying degrees in different parts of the species range. This is, among others, the case of mono- and polycaly of *F. pratensis*: in northern Europa (Scandinavia) there is only a monocalic form, but in Central Europe a polycalic form occurs sporadically, which is common in the south. This is probably a reflection of the variable rates of mono- and polygyny in this geographical gradient (see Czechowski, 1996; Czechowski et al., 2012). Similarly, *F. pressilabris* is monocalic and monogynous in Russia, and polycalic and polygynous in Central Europe (see Czechowski, 1975; Czechowski et al., 2012). Previous studies with *F. pratensis* in Sweden showed that aggression level in this species is positively correlated with the genetic distances of the colonies (Beye et al., 1998; Pirk et al., 2001). These two studies also reported that the aggression level between colonies increased with increasing distance separating them, as an example of the dear enemy phenomenon. However, in a recent study, Benedek and Kobori (2014) reported evidence for a nasty neighbor effect in *F. pratensis* upon finding that the behavior of workers from adjacent colonies was more aggressive than those from nonadjacent colonies in Romania. The variations determined in aggressive behavior in *F. pratensis* were also reported for some other ant species (Thomas et al., 1999; Stuart and Herbers, 2000; van Wilgenburg, 2007).

Therefore, more data are needed to clarify how genetic diversity and physical distance affect the aggression level of individuals in monodomous and polydomous colonies of *F. pratensis* and to determine whether there is a generalization or plasticity in the aggression behavior in this species. For this purpose, we determined the level of aggression between individuals of different colonies both in nature and laboratory conditions, and analyzed the genetic relatedness of the colonies through DNA barcoding (partial mitochondrial COI gene) and therefore evaluated the effect of genetic and spatial distance on level of aggression.

2. Materials and methods

2.1. The ants and the study area

Nine *Formica pratensis* colonies in five localities in different parts of the Thrace Region in Turkey were included in the study (Figure 1). *F. pratensis* is one of the two wood ant species in Turkey and is distributed only in the Thrace Region of the country, where it is represented by very low numbers of colonies scattered mostly in the northern woodland parts of the region (Aktac et al., 1998; Kiran and Karaman, 2012). Two localities containing three neighboring nests in each were considered as multiple nest-bearing localities (Balaban and Ahmetler villages, see Figure 1), whilst other localities were represented by only one nest in each. The distances between the colonies ranged from 22 to 90 m in multiple nest-bearing localities and from 17 to 83 km between localities. Prior to the study, localities with multiple sympatric colonies were visited many times to see if those colonies were part of a polydomous system or not. Field observations in these localities revealed that no intertraffic occurred between the three colonies in Ahmetler, while two colonies in Balaban were connected to each other. Therefore, in addition to all single colonies in other localities, both all colonies in Ahmetler and the third colony in Balaban, which is not connected with the other two colonies, were considered monodomous, while the two other interconnected colonies in Balaban were considered polydomous.

2.2. Behavioral experiments

All behavioral experiments were performed in June 2014 when workers showed intense activity in the field. The level of aggression between colonies was tested both in nature and laboratory conditions as dyadic encounters lasting for 2 min. Experiments in nature were performed by gently placing an individual worker of a colony (the donor) on the nest surface of another colony (the recipient) and by recording the behavioral responses of the recipient workers towards the donors. All donor workers were color marked with a drop of Tipp-ex correction fluid (solvent free) on their gasters to follow them easily on the recipient nest surface. Since colonies were distributed over a wide area inside the study region, a small portion of the nests were taken with a couple of hundred workers without brood in separate plastic boxes (subnest) from which escape was prevented by Fluon (Sigma-Aldrich, MO, USA) coating its walls. By doing so, the nests were paired with each other in nature for the behavioral assay. The marking of workers both in the field and in the laboratory tests had no effect on their aggression levels (see also Souza et al., 2006; Velásquez et al., 2006; Martin et al., 2008; Benedek and Kobori, 2014). When a subnest was used as the donor nest, it was kept still near the recipient colony for a sufficient time to prevent workers from performing unwanted alarm-like behaviors before and during tests. The behavioral responses of

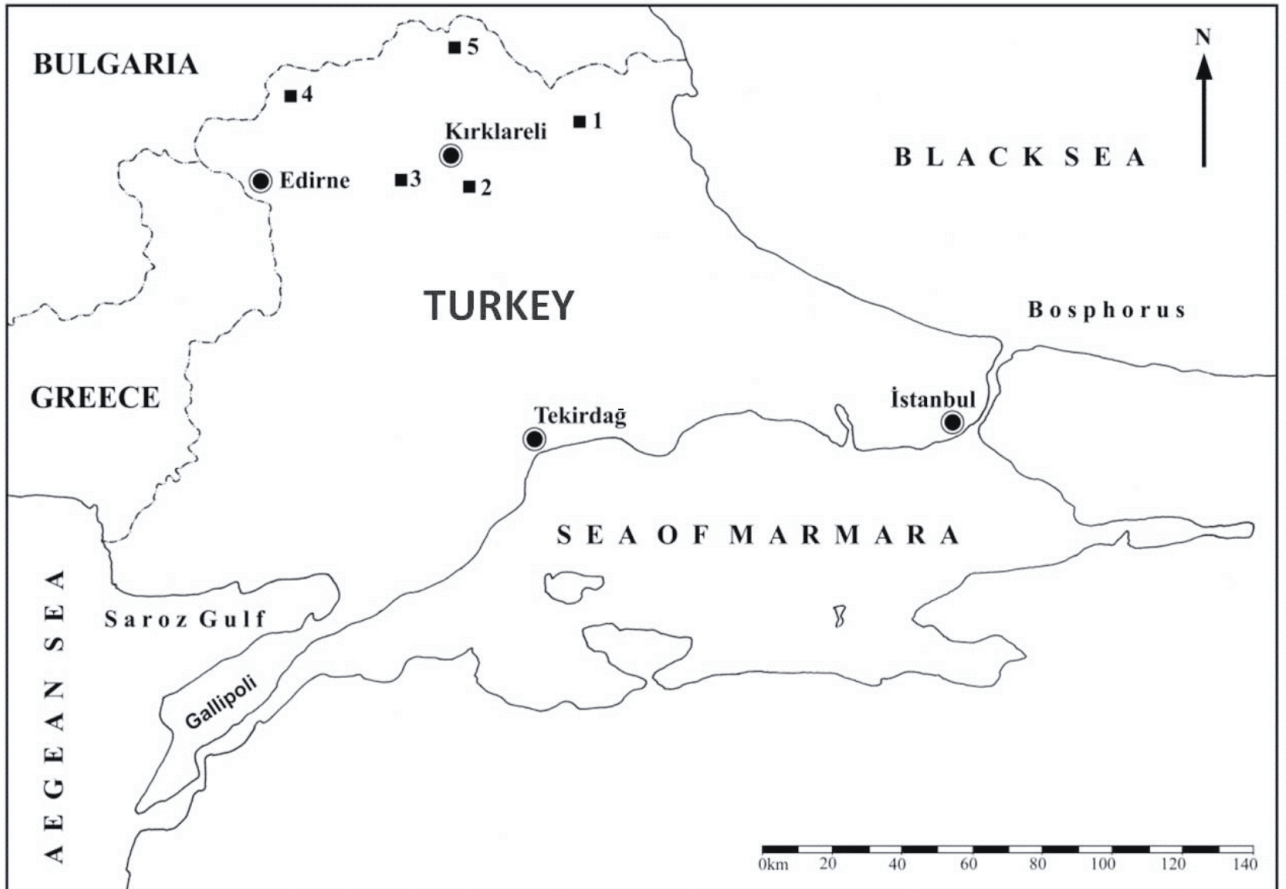

Figure 1. Map showing the localities where *F. pratensis* colonies were sampled for the analysis of genetic relatedness and tested for their aggressive behavior towards each other. The numbers denote the localities. 1: Balaban village (N 41°49'18", E 27°40'44") containing three nests; B1, B2, and B3, 2: Asilbeyli village (N 41°39'32", E 27°13'50"), one nest (As), 3: Ulukonak village (N 41°39'35", E 27°01'52") one nest (U), 4: Doğanköy village (N 41°56'12", E 26°41'20") one nest (D), and 5: Ahmetler village (N 42°00'37", E 27°11'12"), three nests; Ah1, Ah2, and Ah3.

the recipient workers towards the donor workers were observed and scored on a numerical scale of increasing aggressive behavior (1 to 9) (see Table) based on the behavioral observations given by Obin and Vander Meyer

(1988). Each pair of nests was tested in five replicates. The average of interactions was used as a behavioral score for a particular test pair in further statistical analysis.

Table. Behavioral units and aggression scores used (see also Obin and Vander Meyer 1988).

Score	Behavioral units
9	Immediately fight, acid spraying, gaster in typical bent position of defense.
8	Siding, antenna-leg biting followed by acid spraying.
7	As in score 8, but biting ends.
6	As in score 7 but no gaster bending.
5	Alarm, running, avoidance, holding and vibrating the gaster in upright position.
4	Mandibles open, an immediate antennal contact and siding.
3	An immediate antennal contact not more than 2 s.
2	An immediate antennal contact longer than 2 s and following, staying still if the other ant is not moving.
1	As in the score 2 but no following or staying still behavior.

Field aggression tests were followed by laboratory tests. All subnests were brought to a controlled laboratory environment in the Behavioral Ecology Laboratory in the Department of Biology at Trakya University. The laboratory provided the ants a constant level of humidity (50%) and temperature (28–30 °C) and a 12:12 h light/dark regime. All subnests were allowed to get accustomed to laboratory conditions for 2 weeks during which they were fed with 50% sucrose solution and freshly collected dead grasshoppers. The feeding regime was also continued during the experiments and was the same for all laboratory colonies. Laboratory tests were performed in a similar manner to field experiments except that the workers from a pair of two subnests were allowed to meet each other not on one of the laboratory nests but in a separate plastic test box in which cardboard was used to divide the box into two compartments. Before each test, one of the workers in the pair was color marked on its gaster and then both workers were gently placed in separate compartments. Prior to the test the separating cardboard was removed gently and then behavioral interactions of the workers were observed and scored for 2 min as described above. Each pair of subnests was also tested in five replicates as in the case of the field experiments.

2.3. Statistical analysis

Multiple regression analysis was performed to determine if monodomy/polydomy and the spatial distances between the colonies are associated with the level of aggression. Spearman correlation analysis was used to reveal the relationship between the level of aggression in the field and the spatial distances between the nests. The Mann–Whitney U test was run to determine if there were differences in level of aggression i) in the field and laboratory tests and ii) in the field tests of monodomous and polydomous colonies. All statistical analyses were performed in SPSS version 19.0 for Windows (SPSS, Chicago, IL, USA). $P < 0.05$ was used to denote statistical significance.

2.4. Testing of genetic relatedness

2.4.1. DNA isolation

DNA extraction of *F. pratensis* was conducted using the procedure below. Only the thoraxes of the workers were used in isolations. Thoraxes were removed from the rest of the body and cut into pieces using a scalpel. Tissue pieces were placed in a microcentrifuge tube containing 300 µL of CTAB (Sigma-Aldrich, USA) buffer and homogenized. Then 300 µL of CTAB and 50 µL of β-mercaptoethanol (Sigma-Aldrich, USA) were added and the content was mixed by vortexing.

After incubation for 1 h at 65 °C, 500 µL of chloroform:isoamyl alcohol (24:1, v/v) was added and the mixture was centrifuged at 13,000 rpm for 20 min at 4 °C. The supernatant was then transferred to a new microcentrifuge tube, 500 µL of ice-cold isopropanol was added, and the tube content was mixed gently. The mixture

was incubated at –20 °C for 1 h and then centrifuged at 13,000 rpm for 10 min at 4 °C. After discarding the supernatant, the precipitate was washed with 70% ethanol twice and with 100% ethanol for once and left to dry in a laminar flow cabinet (NÜVE, Turkey). Next, 500 µL of Tris-EDTA (TE) buffer and 2 µL of RNase were added and the tubes were incubated at 37 °C for 1 h. Then 500 µL of phenol:chloroform:isoamyl alcohol (25:24:1, v/v/v) was added to the mixture and it was centrifuged at 10,000 rpm for 15 min at 4 °C. The supernatant was transferred to a new tube and 500 µL of chloroform:isoamyl alcohol (24:1, v/v) was added. The mixture was mixed gently, centrifuged at 13,000 rpm for 10 min at 4 °C, and the supernatant was again transferred to a new tube to which 500 µL of 3M sodium acetate and 500 µL of ethanol were added. The tube was centrifuged at 13,000 rpm for 15 min at 4 °C, the supernatant was discarded, and the pellet was dried. Then 100 µL of TE buffer was added to the tubes to dissolve the DNA and the DNA samples were kept at –20 °C until the PCR procedure.

2.4.2. PCR protocol

The extracted DNA was used as an amplification template for PCR analysis. An approximately 861-bp fragment of the mtDNA cytochrome oxidase I (COI) gene was amplified by PCR (Thermal Cycler PCR, MWG Biotech). The PCR amplifications were done in reaction volumes of 50 µL containing 20 ng of template DNA, 1X PCR Rxn buffer, 1.5 unit (U) of *Taq* DNA polymerase (Promega, USA), 10 pmol/µL of each forward and reverse primer [L-2161_F (5' CAACATTTATTTTGATTYTTTG 3') and H-3038_R (5' TCCAATGCACTAATCTGCCATATTG 3')], 0.2 mM of dNTP, and 1.5 mM of MgCl₂. PCR conditions were as follows: 1 min at 95 °C followed by 30 cycles of 1 min at 94 °C, 1 min at 55 °C, and 1 min at 72 °C, with a final extension of 4 min at 72 °C.

2.4.3. DNA sequencing, haplotyping, and neighbor joining analysis

An 820-bp portion of the COI gene was sequenced using the two primers. After sequencing, the Bioedit program was used for sequence alignment and the DNA sequence was aligned for each of the nine samples. The DNA sequences in FASTA format were transferred to DnaSP software and the number of different haplotypes was determined. The resulting sequences, the haplotypes, were aligned to the COI sequence of the ant *Formica fusca* obtained from GenBank (<https://www.ncbi.nlm.nih.gov/nucleotide/41058509>, accession no: AY334398). Genetic distances were estimated using the Kimura-2-parameter (Kimura, 1980) distances with MEGA 5 (Tamura et al., 2011). The phylogenetic tree was estimated using neighbor joining (Saitou and Nei, 1987) in MEGA 5. The reliability of trees was tested with a bootstrap test including 1000 resamplings (Felsenstein, 1985).

3. Results

3.1. Intraspecific aggressiveness

Except for the pairs in which the members of the polydomous colony in Balaban (B1 and B2) were present, the aggression levels in the field were the same irrespective of which nest is the donor or the recipient. Therefore, the results of only one of the encounters in a particular pair of monodomous colonies were given.

The regression analysis, based on spatial distances and type of colonies (mono- and polydomous), of aggression levels of all colonies in the field showed that spatial distance had no effect on the level of aggression ($P = 0.285$) while mono- and polydomy of the colonies significantly affected the aggression levels ($P < 0.001$). The high aggression of the recipient monodomous colonies towards either neighboring or distant conspecifics (mean aggression score \pm SD: 8.5 ± 0.64) showed that a high level of intraspecific aggression was present (Figure 2A). In contrast, the level of aggression of the recipient polydomous colony was comparatively low (mean aggression score \pm SD: 4.4 ± 2.28 , Figure 2B). The difference between aggression levels of monodomous and polydomous colonies in the field was statistically significant (Mann-Whitney U test; $U = 177.5$, $Z = -8.205$, $P < 0.05$).

The results also demonstrated that the level of aggression determined in the field decreased in laboratory encounters (mean aggression score \pm SD: 3.9 ± 1.9 , Figure 2C). The difference between aggression levels in the field and laboratory tests was statistically significant (Mann-Whitney U test; $U = 883.5$, $Z = -13.881$, $P < 0.05$).

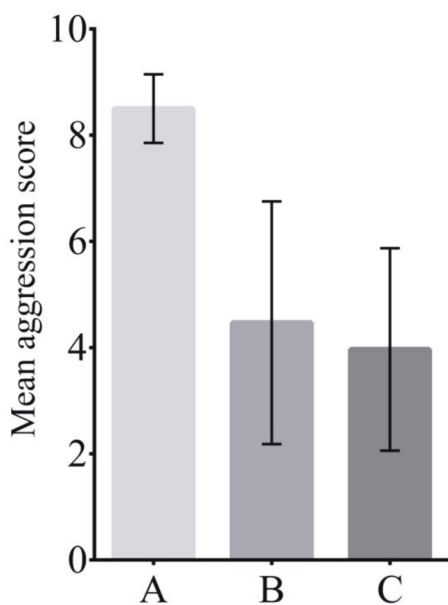

Figure 2. Mean aggression levels in monodomous (A) and polydomous (B) colonies in the field and in laboratory conditions (C).

When the aggression levels of monodomous and polydomous colonies were analyzed individually, a strong positive correlation was found between spatial distance and the level of aggression of the polydomous colony ($r = 0.855$; $P < 0.001$, Figure 3); that is, the level of aggression of workers of the polydomous colony increased with increasing spatial distance to the donor colonies. The correlation analysis revealed a moderate negative correlation with spatial distance and the level of aggression of monodomous colonies ($r = -0.443$; $P < 0.001$, Figure 3).

3.2. Genetic relatedness

The sequencing and phylogenetic analysis of COI gene sequences of *F. pratensis* workers of nine different colonies showed the presence of six different types of haplotypes. Figure 4 shows the neighbor joining tree obtained through MEGA. The tree revealed that the haplotypes of the ants from the colonies in the Asilbeyli, Ahmetler (Ah2), Ulukonak, Ahmetler (Ah1), and Doğanköy formed a group, the haplotype of the ants from Ahmetler (Ah3) colony was the haplotype closest to this group, and the haplotype of the ants from the three colonies in Balaban was the farthest from both.

4. Discussion

Our results show that the level of intraspecific aggression in *Formica pratensis* colonies in our study area is guided by both endogenous (genetic) and exogenous (environmental) factors. The high level of aggressive behavior observed in all field encounters of workers of monodomous colonies, even those from neighboring sympatric colonies (i.e. Ahmetler colonies), indicates that aggression in monodomous colonies was not correlated with their spatial distances. The genetic relatedness of the monodomous colonies also had no effect on the level of aggression. On the other hand, the low aggression of the polydomous colony towards genetically and spatially

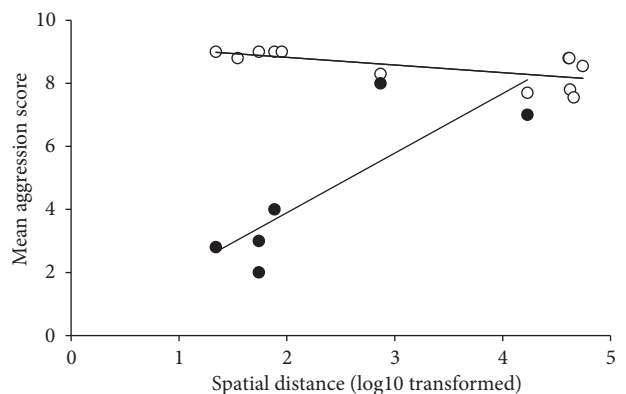

Figure 3. Correlation between spatial distance and aggression levels in the field. Open circles correspond to monodomous colonies and filled circles correspond to the polydomous one.

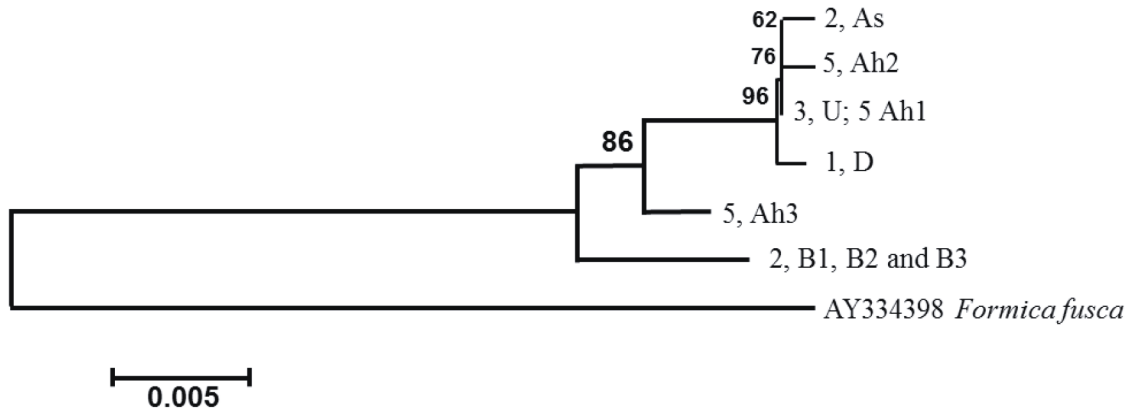

Figure 4. Neighbor-joining tree of genetic distances of the COI gene for *F. pratensis* sampled from nine colonies. Numbers on the nodes show the bootstrap values (>50%) and the numbers and the abbreviations at the end of the branches denote the localities and the nest IDs, respectively.

close conspecifics and their increased aggression towards distant colonies showed that both genetic relatedness and spatial distance affected the aggressive responses of the polydomous colony. According to Pisarski (1982), monodomous colonies of territorial ant species were more aggressive than polydomous ones.

In some of the previous studies with *F. pratensis*, intraspecific aggression was determined to be correlated both with the genetic and geographical distances between the colonies (Beye et al., 1998; Pirk et al., 2001). In contrast, Kiss and Kóbori (2014) reported for a population from Fânațele Clujului in Romania that the behavior of workers from adjacent colonies was more aggressive than those from nonadjacent ones. This type of neighbor-directed aggression is known as the nasty neighbor effect, in which workers are more aggressive towards territorial neighbors. This has been shown for other ant species, i.e. *Pogonomyrmex barbatus*, *Iridomyrmex purpureus*, *Linepithema humile*, and *Pristomyrmex pungens*, as well (Gordon, 1989; Thomas et al., 1999, 2006; Sanada-Morimura et al., 2003). The discrepancy in aggression levels of different populations studied so far indicates plasticity in the aggressive behavior of *F. pratensis*. Aggressive behaviors of other ant species from different populations were also reported to differ (Thomas et al., 1999; Stuart and Herbers, 2000; van Wilgenburg, 2007). Thomas et al. (1999) showed that nonnestmate aggression in *Iridomyrmex purpureus* was influenced by the density of surrounding conspecific nests. Workers from sites with a higher density of nests tended to be more aggressive than those from less dense sites. This may be explained by the fact that neighboring colonies avoid each other in order to prevent massive and energetically expensive fighting (Hölldobler, 1976). Some of the colonies in our study were alone-standing colonies so that they had no chance

of previous intraspecific encounters in their surroundings. From this point of view, the aggressive behavior of these colonies towards nonnestmates cannot be only explained by intraspecific competition.

An important outcome of our results is that the colonies in multinest-bearing areas behaved differently in the field tests. Although the three colonies in Ahmetler village (Ah1, Ah2, and Ah3) were closely located, neither internest traffic between the colonies nor a common use of a trail or a food source was determined. Moreover, these colonies behaved aggressively not only to distant colonies but also to each other. The clear territorial separation of the colonies leading to formation of nonoverlapping trunk trails and foraging grounds led each colony to limit the intrusion of neighboring foragers inside their nesting and foraging territories. Territoriality predicts ants to be less aggressive towards their neighbors than towards unfamiliar conspecifics to minimize costs associated with territory defense (Wilson, 1975). In contrast to this prediction, the highly aggressive behavior of spatially close monodomous colonies in Ahmetler (Ah1, Ah2, and Ah3) towards each other shows that the potential losses to neighbors should be as costly as potential losses to strangers. In addition, the low genetic similarity determined for these colonies indicates an independent formation for each of the colonies. The inevitable result of such an independent formation is the lack of common recognition cues due to low genetic relatedness. Therefore, each colony has its own recognition label making them highly aggressive to each other.

In Balaban, on the other hand, we obtained different results with the three sympatric colonies. The low level of aggression determined in the two interconnected colonies in Balaban (B1 and B2) confirms polydomy for these colonies. It seems that continuous worker

exchange between these two nests led to the formation of a recognition system based on repeated encounters of workers and familiarization with the nest-associated cues. In addition, high genetic relatedness between Balaban colonies might be an indication that the three nests are probably a result of budding of a natal nest. In polydomous colonies, the lack of aggression between workers from neighboring nests reflects their common origin (Helanterä et al., 2009). Polydomy and budding allows the maintenance of a strong population genetic structure, whereas distant colonies are more genetically differentiated than neighboring ones (Zinck et al., 2007). Although a high genetic relatedness was determined between Balaban colonies, the two colonies for which internest traffic was observed behaved differently compared to the other colony (the monodomous one, B3), which had no contact with the others. The polydomous colony exhibited a decreased aggression towards nonnestmates in the same area but the level of aggression of the monodomous colony was always at high levels even to its neighbors. It is also important to underline the fact that the decreased aggression of the polydomous colony towards nonnestmates increased with increasing distance. This shows that environmental cues are as effective as genetic cues on aggressive decisions of workers of the polydomous colony. If this colony is governed by more than one reproductive queen, then polygyny can explain the decreased aggression towards close relatives. If recognition cues are assumed to be genetically determined, at least partly, presence of multiple reproducing queens will increase the genetic diversity and in turn recognition cue diversity of a colony, which could result in low levels of aggression.

Pirk et al. (2001) reported that there was no difference in the aggression levels of monodomous and polydomous colonies of *F. pratensis*. However, our results revealed different aggression levels for such colonies. The level of genetic relatedness and environmental cues are both involved in polydomous colony aggression. When the monodomous colony is considered, it appears that environmental factors overrode the genetic relatedness in their effects on aggression. A wide and very crowded trunk trail originating from the monodomous colony in Balaban was determined leading the foragers to a big tree that provided aphid honeydew and this foraging area was monopolized by this colony. This monopolization might have decreased the level of repeated encounters with the foragers of the other colonies and therefore can be considered an important factor that led to elevated aggression of this colony.

Indiscriminate aggressive behavior shown by workers of monodomous *F. pratensis* colonies towards not only nonneighboring but also neighboring conspecifics

opposes the dear enemy effect and rather fits the nasty neighbor effect. Studies of different animals showed that less aggression is shown toward neighbors than towards strangers (dear enemy effect) but the opposite can also be true, namely, the nasty neighbor effect (Newey et al., 2010). The nasty neighbor effect was previously shown for a Romanian population of *F. pratensis* by Benedek and Kóbori (2014). On the other hand, Beye et al. (1998) and Pirk et al. (2001) reported a reduced aggression level for Öland (Sweden) populations of *F. pratensis*. The results reported by Pirk et al. (2001) demonstrated that neighboring colonies were genetically more related than distant colonies, which may reflect budding as a possible spreading mechanism. This apparently coincides with the correlation between the level of aggression and the spatial distance between the colonies, namely the dear enemy effect. Dear enemy relationships have also been suggested for a number of ant species [*Acromyrmex octospinosus* (Jutsum et al., 1979), *Leptothorax nylanderi* (Heinze et al., 1996), *Pheidole tucsonica* and *Ph. gilvoscens* (Langen et al., 2000), and *Cataglyphis fortis* (Knaden and Wehner, 2003)].

The differences between aggression levels determined in the field and in laboratory conditions show that aggression in *F. pratensis* is context dependent. One might expect ants to assess different factors to determine the level of their aggressive behaviors during intraspecific competitive interactions. Competitor familiarity, habitat type, season, and resource value can be context factors affecting competitive behaviors. Evidence for context-dependent aggression and the importance of a familiar territory for defense was reported in various social insects (Hölldobler and Lumsden, 1980; Pfennig and Reeve, 1980; Tanner and Adler, 2009; Couvillon et al., 2013). In a study with *Formica xerophila* and *F. integroides*, Tanner and Adler (2009) reported that competitive encounters within an individual's territory yielded more aggressive interactions than encounters in a neutral arena and aggression increased with resource value. In our case, the nests in the field on which the aggression tests were performed are clearly the most important place to be defended and the laboratory conditions represent the neutral arena. It was reported that aggression towards nonnestmates increases with increasing proximity to the nest (Gamboa et al., 1991; Starks et al., 1998). If we assume that colony-specific odors signal the proximity of the nest, then we can explain the decreased aggression of *F. pratensis* in laboratory conditions. Moreover, the absence of familiar nestmates may signal that the nest is relatively distant and individuals thereby perceive no threat of colony resource usurpation. Several laboratory studies have found that ants' aggressiveness diminishes with the distance from the colony entrance (Mayade et al.,

1993; Knaden and Wehner, 2003). Mayade et al. (1993) distinguished two kinds of spatial areas outside the nest of *Cataglyphis cursor*. They identified an area located nearby the colony's entrance, where resident ants are considerably more aggressive than intruders, and a second area, located at further distance from the nest, where resident ants show lower aggressiveness than at the nest entrance. Similarly, Knaden and Wehner (2003) found that readiness of foragers of *Cataglyphis fortis* to fight against conspecific ants was significantly higher in workers captured close to the nest entrance compared to the ants captured at a 5-m distance from the nest entrance. Although there are studies reporting that the role of exogenous cues in aggression is minor and therefore there is a small change in the pattern of intraspecific aggression over time (Holway et al., 1998; Suarez et al., 2002), the lack of environmental cues, which increases action threshold, can also account for the decreased aggression in the laboratory. For instance, Chen and Nonacs (2000) recorded a complete loss of aggression of *L. humile* colonies reared for 2 months in uniform laboratory conditions, which suggests a primary role for environmentally derived cues.

References

- Aktac N, Camlitepe Y, Aras A, Kiran K. (1998) A comparative study on the distribution of *Formica rufa* group (Hymenoptera: Formicidae) in Turkish Thrace and Anatolia. II. International Congress on Biodiversity, Ecology and Conservation of the Balkan Fauna. Bioecco2, 16–20 September 1998; Ohrid, Macedonia, p. 69.
- Benedek K, Kóbori OT (2014). 'Nasty neighbor' effect in *Formica pratensis* Retz. (Hymenoptera: Formicidae). North-West J Zool 10: 245-250.
- Bennett B (1989). Nestmate recognition systems in a monogynous polygynous species pair of ants (Hymenoptera: Formicidae). I. Worker and queen derived cues. Sociobiology 16: 121-139.
- Beye M, Neumann P, Chapuisat M, Pamilo P, Moritz RFA (1998). Nestmate recognition and the genetic relatedness of nests in the ant *Formica pratensis*. Behav Ecol Sociobiol 43: 67-72.
- Bos N, d'Ettorre P (2012). Recognition of social identity in ants. Front Psychol 3: 1-6.
- Czechowski W (1975). Bionomics of *Formica (Coptoformica) pressilabris* Nyl. (Hymenoptera, Formicidae). Annales Zoologici 33: 103-125.
- Czechowski W (1996) Colonies of hybrids and mixed colonies; interspecific nest takeover in wood ants (Hymenoptera, Formicidae). Memorabilia Zoologica 50: 1-116.
- In conclusion, the aggressive behavior of *F. pratensis* in our study showed that genetic and environmental cues are the determinants of the level of aggression and the effects of these cues on aggression differed based on the social structure of the colonies. Our results also showed that the context-dependent aggressive behavior might be considered a defense mechanism that denotes a fitness payoff for active defense and informs the workers to decide to share the cost of nest defense in groups, but not alone. The similarities and discrepancies with previous studies with *F. pratensis* show that there is no general pattern in the behavior of the species and the plasticity seen in different populations underlines the success of colonies in adaptation to local scale pressures.
- Acknowledgments**
This research was supported by the Scientific and Technological Research Council of Turkey (TÜBİTAK – Project No. 212T118). The authors thank Prof Dr İslam Gündüz from Ondokuz Mayıs University, Samsun, Turkey, for his help with the genetic analysis and Prof Dr Necdet Süt from Trakya University, Edirne, Turkey, for his help with the statistical analyses.
- Czechowski W, Radchenko A, Czechowska W, Vepsäläinen K (2012). The Ants of Poland with Reference to the Myrmecofauna of Europe. Warsaw, Poland: Museum and Institute of Zoology of the Polish Academy of Sciences and Natura optima dux Foundation, pp. 496.
- Chen JSC, Nonacs P (2000). Nestmate recognition and intraspecific aggression based on environmental cues in Argentine ants (Hymenoptera: Formicidae). Ann Entomol Soc Am 93: 1333-1337.
- Chapuisat M, Bernasconi C, Hoehn S, Reuter M (2005). Nestmate recognition in the unicolonial ant *Formica paralugubris*. Behav Ecol 16: 15-19.
- Couvillon MJ, Segers FHID, Cooper-Bowman R, Truslove G, Nascimiento DL, Nascimiento FS, Ratnieks FSL (2013). Context affects nestmate recognition errors in honey bees and stingless bees. J Exp Biol 216: 3055-3061.
- Felsenstein J (1985). Confidence limits on phylogenies: an approach using the bootstrap. Evolution 39: 783-791.
- Foitzik S, Sturm H, Pusch K, d'Ettorre P, Heinze J (2007). Nestmate recognition and intraspecific chemical and genetic variation in *Temnothorax* ants. Anim Behav 73: 999-1007.
- Gamboa GJ, Reeve HK, Holmes WG (1991). Conceptual issues and methodology in kin-recognition research: a critical discussion. Ethology 88: 109-127.

- Gordon DM (1989). Ants distinguish neighbors from strangers. *Oecologia* 81: 198-200.
- Guerrieri FJ, Nehring V, Jorgensen CG, Nielsen J, Galizia CG, d'Ettorre P (2009). Ants recognize foes not friends. *Proc R Soc Lond B Biol Sci* 276: 2461-2468.
- Heinze J, Foitzik S, Hippert A, Hölldobler B (1996). Apparent dear-enemy phenomenon and environment-based recognition cues in the ant *Leptothorax nylanderi*. *Ethology* 102: 510-522.
- Helantera H, Strassmann JE, Carrillo J, Queller DC (2009). Unicolonial ants: where do they come from, what are they and where are they going? *Trends Ecol Evol* 24: 341-349.
- Hölldobler B (1976). Recruitment behaviour, home range orientation and territoriality in harvester ants, *Pogonomyrmex*. *Behav Ecol Sociobiol* 1: 3-44.
- Hölldobler B, Lumsden CJ (1980). Territorial strategies in ants. *Science* 210: 732-739.
- Holway DA, Suarez AV, Case TJ (1998). Loss of intraspecific aggression in the success of a widespread invasive social insect. *Science* 282: 949-952.
- Holzer B, Chapuisat M, Kremer N, Finet C, Keller L (2006). Unicoloniality, recognition and genetic differentiation in a native *Formica* ant. *J Evolution Biol* 19: 2031-2039.
- Jutsum A, Saunders T, Cherrett J (1979). Intraspecific aggression in the leaf-cutting ant *Acromyrmex octospinosus*. *Anim Behav* 27: 839-844.
- Kimura M (1980). A simple method for estimating evolutionary rates of base substitutions through comparative studies of nucleotide sequences. *J Mol Evol* 16: 111-120.
- Kiran K, Karaman C (2012). First annotated checklist of the ant fauna of Turkey (Hymenoptera: Formicidae). *Zootaxa* 3548: 1-38.
- Kiss K, Kóbori O (2010). Low intraspecific aggression at polydomous colonies of *Formica exsecta* (Hymenoptera: Formicidae). *Entomologica Romanica* 16: 27-32.
- Knaden M, Wehner R (2003). Nest defense and conspecific enemy recognition in the desert ant *Cataglyphis fortis*. *J Insect Behav* 16: 717-730.
- Langen TA, Tripet F, Nonacs P (2000). The red and the black: habituation and the dear-enemy phenomenon in two desert *Pheidole* ants. *Behav Ecol Sociobiol* 48: 285-292.
- Lenoir A, d'Ettorre P, Errard C, Hefetz A (2001). Chemical ecology and social parasitism in ants. *Annu Rev Entomol* 46: 573-599.
- Liang D, Silverman J (2000). "You are what you eat": diet modifies cuticular hydrocarbons and nestmate recognition in the Argentine ant, *Linepithema humile*. *Natunwissenschaften* 87: 412-416.
- Martin SJ, Drijfhout FP (2009). Nestmate and task cues are influenced and encoded differently within ant cuticular hydrocarbon profiles. *J Chem Ecol* 35: 368-374.
- Martin SJ, Vitikainen E, Helantera H, Drijfhout FP (2008). Chemical basis of nest-mate discrimination in the ant *Formica exsecta*. *Proc Biol Sci B* 275: 1271-1278.
- Mayade S, Cammaerts MC, Suzzoni JP (1993). Home-range marking and territorial marking in *Cataglyphis cursor* (Hymenoptera, Formicidae). *Behav Proc* 30: 131-142.
- Morel L, Vander Meer RK, Lofgren CS (1990). Comparison of nestmate recognition between monogyne and polygyne populations of *Solenopsis invicta* (Hymenoptera: Formicidae). *Ann Entomol Soc Am* 83: 642-647.
- Newey PS, Robson SK, Crozier RH (2010). Weaver ants *Oecophylla smaragdina* encounter nasty neighbors rather than dear enemies. *Ecology* 91: 2366-2372.
- Obin MS, Vander Meer RK (1988). Sources of nestmate recognition cues in the imported fire ant *Solenopsis invicta* Buren (Hymenoptera: Formicidae). *Anim Behav* 36: 1361-1370.
- Pfennig DW, Reeve HK (1980). Neighbor recognition and context-dependent aggression in a solitary wasp, *Sphecius speciosus* (Hymenoptera: Sphecidae). *Ethology* 80: 1-18.
- Pirk CWW, Neumann P, Moritz RFA, Pamilo P (2001). Intranest relatedness and nestmate recognition in the meadow ant *Formica pratensis* (R.). *Behav Ecol Sociobiol* 49: 366-374.
- Pisarski B (1982) Influence de la structure sociale sur le comportement agressif des ouvrières de *Formica (Captoformica) exsecta* Nyl. *Memorabilia Zoologica* 38: 113-136.
- Rosengren R, Sundström L, Fortelius W (1993). Monogyny and polygyny in *Formica* ants: the results of alternative dispersal tactics. In: Keller L, editor. *Queen Number and Sociality in Insects*. Oxford, UK: Oxford University Press, pp. 308-333.
- Rosset H, Schwander T, Chapuisat M (2007). Nestmate recognition and levels of aggression are not altered by changes in genetic diversity in a socially polymorphic ant. *Anim Behav* 74: 951-956.
- Roulston TH, Buczkowski G, Silverman J (2003). Nestmate discrimination in ants: effect of bioassay on aggressive behavior. *Insect Soc* 50: 151-159.
- Saitou N, Nei M (1987). The neighbor-joining method: a new method for reconstructing phylogenetic trees. *Mol Biol Evol* 4: 406-425.
- Sanada-Morimura S, Minai M, Yokoyama M, Hirota T, Satoh T, Obara Y (2003). Encounter-induced hostility to neighbors in the ant *Pristomyrmex pungens*. *Behav Ecol* 14: 713-718.
- Seifert B (1996). Ameisen: Beobachten, Bestimmen. Augsburg, Germany: Naturbuch.
- Souza DJ, Della Lucia TMC, Errard C, Richard FJ, Lima ER (2006). Behavioural and chemical studies of discrimination processes in the leaf-cutting ant *Acromyrmex laticeps nigrosetosus* (FOREL, 1908). *Braz J Biol* 66: 863-871.
- Starks PT, Fischer DJ, Watson RE, Melikian GL, Nath SD (1998). Context-dependent nestmate-discrimination in the paper wasp, *Polistes dominulus*: a critical test of the optimal acceptance threshold model. *Anim Behav* 56: 449-458.
- Stuart RJ, Herbers JM (2000). Nest mate recognition in ants with complex colonies: within- and between-population variation. *Behav Ecol* 11: 676-685.

- Suarez AV, Holway DA, Liang DS, Tsutsui ND, Case TJ (2002). Spatio-temporal patterns of intraspecific aggression in the invasive Argentine ant. *Anim Behav* 64: 692-708.
- Sundström L (1997). Queen acceptance and nestmate recognition in monogyne and polygyne colonies of the ant *Formica truncorum*. *Anim Behav* 53: 499-510.
- Tamura K, Peterson D, Peterson N, Stecher G, Nei M, Kumar S (2011). MEGA5: molecular evolutionary genetics analysis using maximum likelihood, evolutionary distance, and maximum parsimony methods. *Mol Biol Evol* 28: 2731-2739.
- Tanner CJ, Adler FR (2009). To fight or not to fight: context-dependent interspecific aggression in competing ants. *Anim Behav* 77: 297-305.
- Thomas ML, Parry LJ, Allen RA, Elgar MA (1999). Geographic affinity, cuticular hydrocarbons and colony recognition in the Australian meat ant *Iridomyrmex purpureus*. *Naturwissenschaften* 86: 87-92.
- Thomas ML, Payne-Makrisa CM, Suarez AV, Tsutsui ND, Holway DA (2006). When supercolonies collide: territorial aggression in an invasive and unicolonial social insect. *Mol Ecol* 15: 4303-4315.
- Torres CW, Brandt M, Tsutsui ND (2007). The role of cuticular hydrocarbons as chemical cues for nestmate recognition in the invasive Argentine ant (*Linepithema humile*) *Insect Soc* 54: 363-373.
- Tsutsui ND, Suarez AV, Grosberg RK (2003). Genetic diversity, asymmetrical aggression, and recognition in a widespread invasive species. *P Natl Acad Sci USA* 100: 1078-1083.
- Vander Meer RK, Morel L (1998). Nestmate recognition in ants. In: Vander Meer RK, Breed MD, Espelie KE, Winston ML, editors. *Pheromone Communication in Social Insects*. Boulder, CO, USA: Westview Press, pp. 79-103.
- van Wilgenburg E (2007). The influence of relatedness, neighbourhood and overall distance on colony mate recognition in a polydomous ant. *Ethology* 113: 1185-119.
- Velásquez N, Gómez M, González J, Vásquez RA (2006). Nest-mate recognition and the effect of distance from the nest on the aggressive behaviour of *Camponotus chilensis* (Hymenoptera: Formicidae). *Behaviour* 143: 811-824.
- Wilson EO (1975). *Sociobiology: the New Synthesis*. Cambridge, MA, USA: Harvard University Press.
- Zinck L, Jaisson P, Hora RR, Denis D, Poteaux C, Doums C (2007). The role of breeding system on ant ecological dominance: genetic analysis of *Ectatomma tuberculatum*. *Behav Ecol* 18: 701-708.